



COVER SHEET

Proposal Submitted By:

Contractor's Name

[Empty text box for Contractor's Name]

Contractor's Address

[Empty text box for Contractor's Address]

City

[Empty text box for City]

State

[Empty text box for State]

Zip Code

[Empty text box for Zip Code]

STATE OF ILLINOIS

Local Public Agency

County of DuPage

County

DuPage

Section Number

22-03000-01-GM

Route(s) (Street/Road Name)

Various Streets in Downers Grove Township

Type of Funds

MFT Funds

Proposal Only Proposal and Plans Proposal only, plans are separate

Submitted/Approved

For Local Public Agency:

For a County and Road District Project

Submitted/Approved

Highway Commissioner Signature

Date

Tammara C. Anderson 7/1/22

Submitted/Approved

County Engineer/Superintendent of Highways

Date

[Empty signature and date boxes]

For a Municipal Project

Submitted/Approved/Passed

Signature

Date

[Empty signature and date boxes]

Official Title

[Empty title box]

Department of Transportation

Released for bid based on limited review

Regional Engineer Signature

Date

[Empty signature and date boxes]

County Engineer on behalf of IDOT pursuant to Agreement of Understanding Dated August 7, 2012

Note: All proposal documents, including Proposal Guaranty Checks or Proposal Bid Bonds, should be stapled together to prevent loss when bids are processed.

Local Public Agency	County	Section Number	Route(s) (Street/Road Name)
County of DuPage	DuPage	22-03000-01-GM	Various Streets in Downers Grove Township

NOTICE TO BIDDERS

Sealed proposals for the project described below will be received at the office of the DuPage County Division of Transportation

<u>421 N. County Farm Road, 2nd Floor, Wheaton, IL 60187</u>	until	<u>2:00 PM</u>	on	<u>08-30-22</u>
Address		Time		Date

Sealed proposals will be opened and read publicly at the office of the DuPage County Division of Transportation

<u>421 N. County Farm Road, 2nd Floor, Wheaton, IL 60187</u>	at	<u>2:00 PM</u>	on	<u>08-30-22</u>
Address		Time		Date

DESCRIPTION OF WORK

Location	Project Length
Downers Grove Township 2022 GM Program	40,710

Proposed Improvement

Milling, 3" Patching, Poly Binder, Surface Paving, Aggregate Shoulders, and Thermoplastic Pavement Markings. Total length of 40,710 feet (8.44 miles)

1. Plans and proposal forms will be available in the office of

on line at <http://www.dupageco.org/dot/doingbusiness>
or by contacting the Division of Transportation at (630) 407-6900.

2. **■ Prequalification**
If checked, the 2 apparent as read low bidders must file within 24 hours after the letting an "Affidavit of Availability" (Form BC 57) in triplicate, showing all uncompleted contracts awarded to them and all low bids pending award for Federal, State, County, Municipal and private work. One original shall be filed with the Awarding Authority and two originals with the IDOT District Office.
3. The Awarding Authority reserves the right to waive technicalities and to reject any or all proposals as provided in BLRS Special Provision for Bidding Requirements and Conditions for Contract Proposals.
4. The following Forms shall be returned by the bidder to the Awarding Authority:
 - a. Local Public Agency Formal Contract Proposal (BLR 12200)
 - b. Schedule of Prices (DuPage County version of BLR 12201)
 - c. Proposal Bid Bond (BLR 12230)
 - d. **DuPage County Apprenticeship or Training Program Certification (all Apprenticeship/Training Registration Number(s) and/or Certificate(s) need to be included with this form)**
 - e. Affidavit of Illinois Business Office (BLR 12326) (do not use for project with Federal funds)
 - f. **DuPage County - Required Vendor Ethics Disclosure Statement**
 - g. **IRS Form W-9: Request for Taxpayer Identification Number and Certification**
 - h. **Three (3) References Form**
5. The quantities appearing in the bid schedule are approximate and are prepared for the comparison of bids. Payment to the Contractor will be made only for the actual quantities of work performed and accepted or materials furnished according to the contract. The scheduled quantities of work to be done and materials to be furnished may be increased, decreased or omitted as hereinafter provided.
6. Submission of a bid shall be conclusive assurance and warranty the bidder has examined the plans and understands all requirements for the performance of work. The bidder will be responsible for all errors in the proposal resulting from failure or neglect to conduct an in depth examination. The Awarding Authority will, in no case, be responsible for any costs, expenses, losses or changes in anticipated profits resulting from such failure or neglect of the bidder.
7. The bidder shall take no advantage of any error or omission in the proposal and advertised contract.
8. If a special envelope is supplied by the Awarding Authority, each proposal should be submitted in that envelope furnished by the Awarding Agency and the blank spaces on the envelope shall be filled in correctly to clearly indicate its contents. When an envelope other than the special one furnished by the Awarding Authority is used, it shall be marked to clearly indicate its contents. When sent by mail, the sealed proposal shall be addressed to the Awarding Authority at the address and in care of the official in whose office the bids are to be received. All proposals shall be filed prior to the time and at the place specified in the Notice to Bidders. Proposals received after the time specified will be returned to the bidder unopened.
9. Permission will be given to a bidder to withdraw a proposal if the bidder makes the request in writing or in person before the time for opening proposals.

Local Public Agency	County	Section Number	Route(s) (Street/Road Name)
County of DuPage	DuPage	22-03000-01-GM	Various Streets in Downers Grove Township

PROPOSAL

1. Proposal of _____ Contractor's Name _____

Contractor's Address _____

2. The plans for the proposed work are those prepared by Morris Engineering, Inc. and approved by the Department of Transportation on 07/01/2022.

3. The specifications referred to herein are those prepared by the Department of Transportation and designated as "Standard Specifications for Road and Bridge Construction" and the " Supplemental Specifications and Recurring Special Provisions" thereto, adopted and in effect on the date of invitation for bids.

4. The undersigned agrees to accept, as part of the contract, the applicable Special Provisions indicated on the "Check Sheet for Recurring Special Provisions" contained in this proposal.

5. The undersigned agrees to complete the work within N/A working days or by 10/29/2022 unless additional time is granted in accordance with the specifications.

6. The successful bidder at the time of execution of the contract will be required to deposit a contract bond for the full amount of the award. When a contract bond is not required, the proposal guaranty check will be held in lieu thereof. If this proposal is accepted and the undersigned fails to execute a contract and contract bond as required, it is hereby agreed that the Bid Bond of check shall be forfeited to the Awarding Authority.

7. Each pay item should have a unit price and a total price. If no total price is shown or if there is a discrepancy between the products of the unit price multiplied by the quantity, the unit price shall govern. If a unit price is omitted, the total price will be divided by the quantity in order to establish a unit price. A bid may be declared unacceptable if neither a unit price nor a total price is shown.

8. The undersigned submits herewith the schedule of prices on BLR 12201 covering the work to be performed under this contract.

9. The undersigned further agrees that if awarded the contract for the sections contained in the combinations on BLR 12201, the work shall be in accordance with the requirements of each individual proposal for the multiple bid specified in the Schedule for Multiple Bids below.

10. A proposal guaranty in the proper amount, as specified in BLRS Special Provision for Bidding Requirements and Conditions for Contract Proposals, will be required. Bid Bonds will be allowed as a proposal guaranty. Accompanying this proposal is either a bid bond, if allowed, on Department form BLR 12230 or a proposal guaranty check, complying with the specifications, made payable to: County Treasurer of DuPage.

The amount of the check is _____ (_____).

Attach Cashier's Check or Certified Check Here

In the event that one proposal guaranty check is intended to cover two or more bid proposals, the amount must be equal to the sum of the proposal guaranties which would be required for each individual bid proposal. If the proposal guaranty check is placed in another bid proposal, state below where it may be found.

The proposal guaranty check will be found in the bid proposal for: Section Number 22-03000-01-GM.

Local Public Agency	County	Section Number	Route(s) (Street/Road Name)
County of DuPage	DuPage	22-03000-01-GM	Various Streets in Downers Grove Township

CONTRACTOR CERTIFICATIONS

The certifications hereinafter made by the bidder are each a material representation of fact upon which reliance is placed should the Department enter into the contract with the bidder.

1. **Debt Delinquency.** The bidder or contractor or subcontractor, respectively, certifies that it is not delinquent in the payment of any tax administered by the Department of Revenue unless the individual or other entity is contesting, in accordance with the procedure established by the appropriate Revenue Act, its liability for the tax or the amount of the tax. Making a false statement voids the contract and allows the Department to recover all amounts paid to the individual or entity under the contract in a civil action.
2. **Bid-Rigging or Bid Rotating.** The bidder or contractor or subcontractor, respectively, certifies that it is not barred from contracting with the Department by reason of a violation of either 720 ILCS 5/33E-3 or 720 ILCS 5/33E-4.

A violation of section 33E-3 would be represented by a conviction of the crime of bid-rigging which, in addition to Class 3 felony sentencing, provides that any person convicted of this offense, or any similar offense of any state or the United States which contains the same elements as this offense shall be barred for 5 years from the date of conviction from contracting with any unit of State or local government. No corporation shall be barred from contracting with any unit of State or local government as a result of a conviction under this Section of any employee or agent of such corporation if the employee so convicted is no longer employed by the corporation: (1) it has been finally adjudicated not guilty or (2) if it demonstrates to the governmental entity with which it seeks to contract that entity finds that the commission of the offense was neither authorized, requested, commanded, nor performed by a director, officer or a high managerial agent on behalf of the corporation.

A violation of Section 33E-4 would be represented by a conviction of the crime of bid-rotating which, in addition to Class 2 felony sentencing, provides that any person convicted of this offense or any similar offense of any state or the United States which contains the same elements as this offense shall be permanently barred from contracting with any unit of State of Local government. No corporation shall be barred from contracting with any unit of State or Local government as a result of a conviction under this Section of any employee or agent of such corporation if the employee so convicted is no longer employed by the corporation and: (1) it has been finally adjudicated not guilty or (2) if it demonstrates to the governmental entity with which it seeks to contract and that entity finds that the commission of the offense was neither authorized, requested, commanded, nor performed by a director, officer or a high managerial agent on behalf of the corporation.

3. **Bribery.** The bidder or contractor or subcontractor, respectively, certifies that, it has not been convicted of bribery or attempting to bribe an officer or employee of the State of Illinois or any unit of local government, nor has the firm made an admission of guilt of such conduct which is a matter or record, nor has an official, agent, or employee of the firm committed bribery or attempted bribery on behalf of the firm and pursuant to the direction or authorization of a responsible official of the firm.
4. **Interim Suspension or Suspension.** The bidder or contractor or subcontractor, respectively, certifies that it is not currently under a suspension as defined in Subpart I of Title 44 Subtitle A Chapter III Part 6 of the Illinois Administrative code. Furthermore, if suspended prior to completion of this work, the contract or contracts executed for the completion of this work may be canceled.

Local Public Agency	County	Section Number	Route(s) (Street/Road Name)
County of DuPage	DuPage	22-03000-01-GM	Various Streets in Downers Grove Township

SIGNATURES

(If an individual)

Signature of Bidder	Date	
<input style="width: 100%; height: 40px;" type="text"/>	<input style="width: 100%; height: 40px;" type="text"/>	
Business Address		
<input style="width: 100%; height: 20px;" type="text"/>		
City	State	Zip Code
<input style="width: 60%; height: 20px;" type="text"/>	<input style="width: 15%; height: 20px;" type="text"/>	<input style="width: 25%; height: 20px;" type="text"/>

(If a partnership)

Firm Name		
<input style="width: 100%; height: 20px;" type="text"/>		
Signature	Date	
<input style="width: 80%; height: 40px;" type="text"/>	<input style="width: 20%; height: 40px;" type="text"/>	
Title		
<input style="width: 100%; height: 20px;" type="text"/>		
Business Address		
<input style="width: 100%; height: 20px;" type="text"/>		
City	State	Zip Code
<input style="width: 60%; height: 20px;" type="text"/>	<input style="width: 15%; height: 20px;" type="text"/>	<input style="width: 25%; height: 20px;" type="text"/>

Insert the Names and Addresses of all Partners

<input type="text"/>

(If a corporation)

Corporate Name		
<input style="width: 100%; height: 20px;" type="text"/>		
Signature	Date	
<input style="width: 80%; height: 40px;" type="text"/>	<input style="width: 20%; height: 40px;" type="text"/>	
Title		
<input style="width: 100%; height: 20px;" type="text"/>		
Business Address		
<input style="width: 100%; height: 20px;" type="text"/>		
City	State	Zip Code
<input style="width: 60%; height: 20px;" type="text"/>	<input style="width: 15%; height: 20px;" type="text"/>	<input style="width: 25%; height: 20px;" type="text"/>

Insert Names of Officers

President
<input style="width: 100%; height: 20px;" type="text"/>

Attest:

Secretary

Secretary

Treasurer

RETURN WITH BID

Contractor's Name:

Local Public Agency: **Downers Grove Township**

County: **DuPage**

Section: **22-03000-01-GM**

Route: **Various locations**

Schedule for Multiple Bids

Combination Letter	Sections included in Combinations	Total

Schedule for Single Bid

(For complete information covering these items, see plans and specifications)

Item No.	Items	Unit	Quantity	Unit Price	Total
1	AGGREGATE SHOULDERS , TYPE "B"	TON	628		
2	BITUMINOUS MATERIALS, TACK COAT	LBS	18863		
3	HMA POLY BINDER BINDER (MM N50)	TON	1451		
4	HMA SURFACE COURSE, MIX "D" N50	TON	2612		
5	DRAINAGE & UTILITY STRUCTURES TO BE ADJUSTED	EACH	8		
6	HMA SURFACE REMOVAL, 2" - VARIABLE	SQ YD	13637		
7	HMA SURFACE REMOVAL (BUTT-JOINTS)	SQ YD	226		
8	HMA SURFACE REMOVAL AT DRIVES	SQ YD	963		
9	PAVEMENT PATCHING - 3" DEPTH	SQ YD	8015		
10	THERMOPLASTIC MARKING - LINE 24"	FOOT	118		
11	TRAFFIC CONTROL AND PROTECTION	EACH	1		



Local Public Agency	County	Section Number
<input type="text"/>	<input type="text"/>	<input type="text"/>

WE, _____ as PRINCIPAL, and

_____ as SURETY, are held jointly, severally and firmly bound unto the above Local Public Agency (hereafter referred to as "LPA") in the penal sum of 5% of the total bid price, or for the amount specified in the proposal documents in effect on the date of invitation for bids, whichever is the lesser sum. We bind ourselves, our heirs, executors, administrators, successors, and assigns, jointly pay to the LPA this sum under the conditions of this instrument.

WHEREAS THE CONDITION OF THE FOREGOING OBLIGATION IS SUCH that, the said PRINCIPAL is submitting a written proposal to the LPA acting through its awarding authority for the construction of the work designated as the above section.

THEREFORE if the proposal is accepted and a contract awarded to the PRINCIPAL by the LPA for the above designated section and the PRINCIPAL shall within fifteen (15) days after award enter into a formal contract, furnish surety guaranteeing the faithful performance of the work, and furnish evidence of the required insurance coverage, all as provided in the "Standard Specifications for Road and Bridge Construction" and applicable Supplemental Specifications, then this obligation shall become void; otherwise it shall remain in full force and effect.

IN THE EVENT the LPA determines the PRINCIPAL has failed to enter into a formal contract in compliance with any requirements set forth in the preceding paragraph, then the LPA acting through its awarding authority shall immediately be entitled to recover the full penal sum set out above, together with all court costs, all attorney fees, and any other expense of recovery.

IN TESTIMONY WHEREOF, the said PRINCIPAL and the said SURETY have caused this instrument to be signed by their respective officers this _____ of _____ Day Month and Year

Principal

Company Name

Signature Date

By:

Title

Company Name

Signature Date

By:

Title

(If Principal is a joint venture of two or more contractors, the company names, and authorized signatures of each contractor must be affixed.)

Surety

Name of Surety

Signature of Attorney-in-Fact Date

By:

STATE OF IL
COUNTY OF

I _____, a Notary Public in and for said county do hereby certify that

(Insert names of individuals signing on behalf of PRINCIPAL & SURETY)

who are each personally known to me to be the same persons whose names are subscribed to the foregoing instrument on behalf of PRINCIPAL and SURETY, appeared before me this day in person and acknowledged respectively, that they signed and delivered said instruments as their free and voluntary act for the uses and purposes therein set forth.

Given under my hand and notarial seal this _____ day of _____ Month and Year

(SEAL)

Notary Public Signature

Date commission expires _____

Local Public Agency

County

Section Number

ELECTRONIC BID BOND

Electronic bid bond is allowed (box must be checked by LPA if electronic bid bond is allowed)

The Principal may submit an electronic bid bond, in lieu of completing the above section of the Proposal Bid Bond Form. By providing an electronic bid bond ID code and signing below, the Principal is ensuring the identified electronic bid bond has been executed and the Principal and Surety are firmly bound unto the LPA under the conditions of the bid bond as shown above. (If PRINCIPAL is a joint venture of two or more contractors, an electronic bid bond ID code, company/Bidder name title and date must be affixed for each contractor in the venture.)

Electronic Bid Bond ID Code

--	--	--	--	--	--	--	--	--	--	--	--	--	--	--

Company/Bidder Name

Signature

Date

Title



Apprenticeship and Training Program Certification

RETURN WITH BID

Local Public Agency	County	Street Name/Road Name	Section Number
County of DuPage	DuPage	Various Street & Sections	22-03000-01-GM

All contractors are required to complete the following certification

- For this contract proposal or for all bidding groups in this deliver and install proposal.
- For the following deliver and install bidding groups in this material proposal.

The County of DuPage policy, adopted in accordance with DuPage County, Illinois County Code, requires this contract to be awarded to the lowest responsive and responsible bidder. The award decision is subject to approval by the Department. In addition to all other responsibility factors, this contract or deliver and install proposal requires all bidders and all bidder's subcontractors to disclose participation in apprenticeship or training programs that are (1) approved by and registered with the United States Department of Labor's Bureau of Apprenticeship and Training, and (2) applicable to the work of the above indicated proposals or groups. Therefore, all bidders are required to complete the following certification:

1. Except as provided in paragraph 4 below, the undersigned bidder certifies that it is a participant, either as an individual or as part of a group program, in an approved apprenticeship or training program applicable to each type of work or craft that the bidder will perform with its own employees.
2. The undersigned bidder further certifies, for work to be performed by subcontract, that each of its subcontractors either (A) is, at the time of such bid, participating in an approved, applicable apprenticeship or training program; or (B) will, prior to commencement of performance of work pursuant to this contract, establish participation in an approved apprenticeship or training program applicable to the work of the subcontract.
3. The undersigned bidder, by inclusion in the list in the space below, certifies the official name of each program sponsor holding the Certificate of Registration for all of the types of work or crafts in which the bidder is a participant and that will be performed with the bidder's employees. Types of work or craft that will be subcontracted shall be included and listed as subcontract work.

4. Except for any work identified above, if any bidder or subcontractor shall perform all or part of the work of the contract or deliver and install proposal solely by individual owners, partners or members and not by employees to whom the payment of prevailing rates of wages would be required, check the following box, and identify the owner/operator workforces and positions of ownership.

The requirements of this certification and disclosure are a material part of the contract, and the contractor shall require this certification provision to be included in all approved subcontracts. The bidder is responsible for making a complete report and shall make certain that each type of work or craft job category that will be utilized on the project is accounted for and listed. The Department at any time before or afterward may require the production of a copy of each applicable Certificate of Registration issued by the United States Department of Labor evidencing such participation by the contractor and any or all of its subcontractors. In order to fulfill the participation requirement, it shall not be necessary that any applicable program sponsor be currently taking or that it will take applications for apprenticeship, training or employment during the performance of the work of this contract or deliver and install proposal.

Bidder	Signature	Date	
<div style="border: 1px solid black; height: 20px;"></div>	<div style="border: 1px solid black; height: 40px;"></div>	<div style="border: 1px solid black; height: 40px;"></div>	
Title			
<div style="border: 1px solid black; height: 20px;"></div>			
Address	City	State	Zip Code
<div style="border: 1px solid black; height: 20px;"></div>	<div style="border: 1px solid black; height: 20px;"></div>	<div style="border: 1px solid black; height: 20px;"></div>	<div style="border: 1px solid black; height: 20px;"></div>



Affidavit of Illinois Business Office



Local Public Agency	County	Street Name/Road Name	Section Number
County of DuPage	DuPage	Various Streets	22-03000-01-GM

I, _____ of _____, _____,
Name of Affiant City of Affiant State of Affiant

being first duly sworn upon oath, state as follows:

1. That I am the _____ of _____.
Officer or Position Bidder
2. That I have personal knowledge of the facts herein stated.
3. That, if selected under the proposal described above, _____, will maintain a business office in the
Bidder
 State of Illinois, which will be located in _____ County, Illinois.
County
4. That this business office will serve as the primary place of employment for any persons employed in the construction contemplated by this proposal.
5. That this Affidavit is given as a requirement of state law as provided in Section 30-22(8) of the Illinois Procurement Code.

Signature	Date
Print Name of Affiant	

Notary Public

State of IL

County _____

Signed (or subscribed or attested) before me on _____ by
(date)

_____, authorized agent(s) of
(name/s of person/s)

Bidder

(SEAL)

Signature of Notary Public

My commission expires _____



Required Vendor Ethics Disclosure Statement

Failure to complete and return this form may result in delay or cancellation of the County's Contractual Obligation.

Date: _____

Bid/Contract/PO #: 22-03000-01-GM

Company Name:	Company Contact:
Contact Phone:	Contact Email:

The DuPage County Procurement Ordinance requires the following written disclosures prior to award:

1. Every contractor, union, or vendor that is seeking or has previously obtained a contract, change orders to one (1) or more contracts, or two (2) or more individual contracts with the county resulting in an aggregate amount at or in excess of \$25,000, shall provide to Procurement Services Division a written disclosure of all political campaign contributions made by such contractor, union, or vendor within the current and previous calendar year to any incumbent county board member, county board chairman, or countywide elected official whose office the contract to be awarded will benefit. The contractor, union or vendor shall update such disclosure annually during the term of a multi-year contract and prior to any change order or renewal requiring approval by the county board. For purposes of this disclosure requirement, "contractor or vendor" includes owners, officers, managers, lobbyists, agents, consultants, bond counsel and underwriters counsel, subcontractors and corporate entities under the control of the contracting person, and political action committees to which the contracting person has made contributions.

NONE (check here) - If no contributions have been made

Recipient	Donor	Description (e.g. cash, type of item, in-kind services, etc.)	Amount/Value	Date Made

2. All contractors and vendors who have obtained or are seeking contracts with the county shall disclose the names and contact information of their lobbyists, agents and representatives and all individuals who are or will be having contact with county officers or employees in relation to the contractor bid and shall update such disclosure with any changes that may occur.

NONE (check here) - If no contacts have been made

Lobbyists, Agents and Representatives and all individuals who are or will be having contact with county officers or employees in relation to the contract or bid	Telephone	Email

A contractor or vendor that knowingly violates these disclosure requirements is subject to penalties which may include, but are not limited to, the immediate cancellation of the contract and possible disbarment from future county contracts.

Continuing disclosure is required, and I agree to update this disclosure form as follows:

- If information changes, within five (5) days of change, or prior to county action, whichever is sooner
- 30 days prior to the optional renewal of any contract
- Annual disclosure for multi-year contracts on the anniversary of said contract
- With any request for change order except those issued by the county for administrative adjustments

The full text for the county's ethics and procurement policies and ordinances are available at:

<http://www.dupageco.org/CountyBoard/Policies/>

I hereby acknowledge that I have received, have read, and understand these requirements.

Authorized Signature

Printed Name

Title

Date

Attach additional sheets if necessary. Sign each sheet and number each page. Page _____ of _____ (total number of pages)

By signing the filled-out form, you:

1. Certify that the TIN you are giving is correct (or you are waiting for a number to be issued),
2. Certify that you are not subject to backup withholding, or
3. Claim exemption from backup withholding if you are a U.S. exempt payee. If applicable, you are also certifying that as a U.S. person, your allocable share of any partnership income from a U.S. trade or business is not subject to the withholding tax on foreign partners' share of effectively connected income, and
4. Certify that FATCA code(s) entered on this form (if any) indicating that you are exempt from the FATCA reporting, is correct. See *What is FATCA reporting*, later, for further information.

Note: If you are a U.S. person and a requester gives you a form other than Form W-9 to request your TIN, you must use the requester's form if it is substantially similar to this Form W-9.

Definition of a U.S. person. For federal tax purposes, you are considered a U.S. person if you are:

- An individual who is a U.S. citizen or U.S. resident alien;
- A partnership, corporation, company, or association created or organized in the United States or under the laws of the United States;
- An estate (other than a foreign estate); or
- A domestic trust (as defined in Regulations section 301.7701-7).

Special rules for partnerships. Partnerships that conduct a trade or business in the United States are generally required to pay a withholding tax under section 1446 on any foreign partners' share of effectively connected taxable income from such business. Further, in certain cases where a Form W-9 has not been received, the rules under section 1446 require a partnership to presume that a partner is a foreign person, and pay the section 1446 withholding tax. Therefore, if you are a U.S. person that is a partner in a partnership conducting a trade or business in the United States, provide Form W-9 to the partnership to establish your U.S. status and avoid section 1446 withholding on your share of partnership income.

In the cases below, the following person must give Form W-9 to the partnership for purposes of establishing its U.S. status and avoiding withholding on its allocable share of net income from the partnership conducting a trade or business in the United States.

- In the case of a disregarded entity with a U.S. owner, the U.S. owner of the disregarded entity and not the entity;
- In the case of a grantor trust with a U.S. grantor or other U.S. owner, generally, the U.S. grantor or other U.S. owner of the grantor trust and not the trust; and
- In the case of a U.S. trust (other than a grantor trust), the U.S. trust (other than a grantor trust) and not the beneficiaries of the trust.

Foreign person. If you are a foreign person or the U.S. branch of a foreign bank that has elected to be treated as a U.S. person, do not use Form W-9. Instead, use the appropriate Form W-8 or Form 8233 (see Pub. 515, *Withholding of Tax on Nonresident Aliens and Foreign Entities*).

Nonresident alien who becomes a resident alien. Generally, only a nonresident alien individual may use the terms of a tax treaty to reduce or eliminate U.S. tax on certain types of income. However, most tax treaties contain a provision known as a "saving clause." Exceptions specified in the saving clause may permit an exemption from tax to continue for certain types of income even after the payee has otherwise become a U.S. resident alien for tax purposes.

If you are a U.S. resident alien who is relying on an exception contained in the saving clause of a tax treaty to claim an exemption from U.S. tax on certain types of income, you must attach a statement to Form W-9 that specifies the following five items.

1. The treaty country. Generally, this must be the same treaty under which you claimed exemption from tax as a nonresident alien.
2. The treaty article addressing the income.
3. The article number (or location) in the tax treaty that contains the saving clause and its exceptions.
4. The type and amount of income that qualifies for the exemption from tax.
5. Sufficient facts to justify the exemption from tax under the terms of the treaty article.

Example. Article 20 of the U.S.-China income tax treaty allows an exemption from tax for scholarship income received by a Chinese student temporarily present in the United States. Under U.S. law, this student will become a resident alien for tax purposes if his or her stay in the United States exceeds 5 calendar years. However, paragraph 2 of the first Protocol to the U.S.-China treaty (dated April 30, 1984) allows the provisions of Article 20 to continue to apply even after the Chinese student becomes a resident alien of the United States. A Chinese student who qualifies for this exception (under paragraph 2 of the first protocol) and is relying on this exception to claim an exemption from tax on his or her scholarship or fellowship income would attach to Form W-9 a statement that includes the information described above to support that exemption.

If you are a nonresident alien or a foreign entity, give the requester the appropriate completed Form W-8 or Form 8233.

Backup Withholding

What is backup withholding? Persons making certain payments to you must under certain conditions withhold and pay to the IRS 24% of such payments. This is called "backup withholding." Payments that may be subject to backup withholding include interest, tax-exempt interest, dividends, broker and barter exchange transactions, rents, royalties, nonemployee pay, payments made in settlement of payment card and third party network transactions, and certain payments from fishing boat operators. Real estate transactions are not subject to backup withholding.

You will not be subject to backup withholding on payments you receive if you give the requester your correct TIN, make the proper certifications, and report all your taxable interest and dividends on your tax return.

Payments you receive will be subject to backup withholding if:

1. You do not furnish your TIN to the requester,
2. You do not certify your TIN when required (see the instructions for Part II for details),
3. The IRS tells the requester that you furnished an incorrect TIN,
4. The IRS tells you that you are subject to backup withholding because you did not report all your interest and dividends on your tax return (for reportable interest and dividends only), or
5. You do not certify to the requester that you are not subject to backup withholding under 4 above (for reportable interest and dividend accounts opened after 1983 only).

Certain payees and payments are exempt from backup withholding. See *Exempt payee code*, later, and the separate Instructions for the Requester of Form W-9 for more information.

Also see *Special rules for partnerships*, earlier.

What is FATCA Reporting?

The Foreign Account Tax Compliance Act (FATCA) requires a participating foreign financial institution to report all United States account holders that are specified United States persons. Certain payees are exempt from FATCA reporting. See *Exemption from FATCA reporting code*, later, and the Instructions for the Requester of Form W-9 for more information.

Updating Your Information

You must provide updated information to any person to whom you claimed to be an exempt payee if you are no longer an exempt payee and anticipate receiving reportable payments in the future from this person. For example, you may need to provide updated information if you are a C corporation that elects to be an S corporation, or if you no longer are tax exempt. In addition, you must furnish a new Form W-9 if the name or TIN changes for the account; for example, if the grantor of a grantor trust dies.

Penalties

Failure to furnish TIN. If you fail to furnish your correct TIN to a requester, you are subject to a penalty of \$50 for each such failure unless your failure is due to reasonable cause and not to willful neglect.

Civil penalty for false information with respect to withholding. If you make a false statement with no reasonable basis that results in no backup withholding, you are subject to a \$500 penalty.

Criminal penalty for falsifying information. Willfully falsifying certifications or affirmations may subject you to criminal penalties including fines and/or imprisonment.

Misuse of TINs. If the requester discloses or uses TINs in violation of federal law, the requester may be subject to civil and criminal penalties.

Specific Instructions

Line 1

You must enter one of the following on this line; **do not** leave this line blank. The name should match the name on your tax return.

If this Form W-9 is for a joint account (other than an account maintained by a foreign financial institution (FFI)), list first, and then circle, the name of the person or entity whose number you entered in Part I of Form W-9. If you are providing Form W-9 to an FFI to document a joint account, each holder of the account that is a U.S. person must provide a Form W-9.

a. **Individual.** Generally, enter the name shown on your tax return. If you have changed your last name without informing the Social Security Administration (SSA) of the name change, enter your first name, the last name as shown on your social security card, and your new last name.

Note: ITIN applicant: Enter your individual name as it was entered on your Form W-7 application, line 1a. This should also be the same as the name you entered on the Form 1040/1040A/1040EZ you filed with your application.

b. **Sole proprietor or single-member LLC.** Enter your individual name as shown on your 1040/1040A/1040EZ on line 1. You may enter your business, trade, or "doing business as" (DBA) name on line 2.

c. **Partnership, LLC that is not a single-member LLC, C corporation, or S corporation.** Enter the entity's name as shown on the entity's tax return on line 1 and any business, trade, or DBA name on line 2.

d. **Other entities.** Enter your name as shown on required U.S. federal tax documents on line 1. This name should match the name shown on the charter or other legal document creating the entity. You may enter any business, trade, or DBA name on line 2.

e. **Disregarded entity.** For U.S. federal tax purposes, an entity that is disregarded as an entity separate from its owner is treated as a "disregarded entity." See Regulations section 301.7701-2(c)(2)(iii). Enter the owner's name on line 1. The name of the entity entered on line 1 should never be a disregarded entity. The name on line 1 should be the name shown on the income tax return on which the income should be reported. For example, if a foreign LLC that is treated as a disregarded entity for U.S. federal tax purposes has a single owner that is a U.S. person, the U.S. owner's name is required to be provided on line 1. If the direct owner of the entity is also a disregarded entity, enter the first owner that is not disregarded for federal tax purposes. Enter the disregarded entity's name on line 2, "Business name/disregarded entity name." If the owner of the disregarded entity is a foreign person, the owner must complete an appropriate Form W-8 instead of a Form W-9. This is the case even if the foreign person has a U.S. TIN.

Line 2

If you have a business name, trade name, DBA name, or disregarded entity name, you may enter it on line 2.

Line 3

Check the appropriate box on line 3 for the U.S. federal tax classification of the person whose name is entered on line 1. Check only one box on line 3.

IF the entity/person on line 1 is a(n) . . .	THEN check the box for . . .
• Corporation	Corporation
• Individual • Sole proprietorship, or • Single-member limited liability company (LLC) owned by an individual and disregarded for U.S. federal tax purposes.	Individual/sole proprietor or single-member LLC
• LLC treated as a partnership for U.S. federal tax purposes, • LLC that has filed Form 8832 or 2553 to be taxed as a corporation, or • LLC that is disregarded as an entity separate from its owner but the owner is another LLC that is not disregarded for U.S. federal tax purposes.	Limited liability company and enter the appropriate tax classification. (P= Partnership; C= C corporation; or S= S corporation)
• Partnership	Partnership
• Trust/estate	Trust/estate

Line 4, Exemptions

If you are exempt from backup withholding and/or FATCA reporting, enter in the appropriate space on line 4 any code(s) that may apply to you.

Exempt payee code.

- Generally, individuals (including sole proprietors) are not exempt from backup withholding.
- Except as provided below, corporations are exempt from backup withholding for certain payments, including interest and dividends.
- Corporations are not exempt from backup withholding for payments made in settlement of payment card or third party network transactions.
- Corporations are not exempt from backup withholding with respect to attorneys' fees or gross proceeds paid to attorneys, and corporations that provide medical or health care services are not exempt with respect to payments reportable on Form 1099-MISC.

The following codes identify payees that are exempt from backup withholding. Enter the appropriate code in the space in line 4.

- 1—An organization exempt from tax under section 501(a), any IRA, or a custodial account under section 403(b)(7) if the account satisfies the requirements of section 401(f)(2)
- 2—The United States or any of its agencies or instrumentalities
- 3—A state, the District of Columbia, a U.S. commonwealth or possession, or any of their political subdivisions or instrumentalities
- 4—A foreign government or any of its political subdivisions, agencies, or instrumentalities
- 5—A corporation
- 6—A dealer in securities or commodities required to register in the United States, the District of Columbia, or a U.S. commonwealth or possession
- 7—A futures commission merchant registered with the Commodity Futures Trading Commission
- 8—A real estate investment trust
- 9—An entity registered at all times during the tax year under the Investment Company Act of 1940
- 10—A common trust fund operated by a bank under section 584(a)
- 11—A financial institution
- 12—A middleman known in the investment community as a nominee or custodian
- 13—A trust exempt from tax under section 664 or described in section 4947

The following chart shows types of payments that may be exempt from backup withholding. The chart applies to the exempt payees listed above, 1 through 13.

IF the payment is for . . .	THEN the payment is exempt for . . .
Interest and dividend payments	All exempt payees except for 7
Broker transactions	Exempt payees 1 through 4 and 6 through 11 and all C corporations. S corporations must not enter an exempt payee code because they are exempt only for sales of noncovered securities acquired prior to 2012.
Barter exchange transactions and patronage dividends	Exempt payees 1 through 4
Payments over \$600 required to be reported and direct sales over \$5,000 ¹	Generally, exempt payees 1 through 5 ²
Payments made in settlement of payment card or third party network transactions	Exempt payees 1 through 4

¹ See Form 1099-MISC, Miscellaneous Income, and its instructions.

² However, the following payments made to a corporation and reportable on Form 1099-MISC are not exempt from backup withholding: medical and health care payments, attorneys' fees, gross proceeds paid to an attorney reportable under section 6045(f), and payments for services paid by a federal executive agency.

Exemption from FATCA reporting code. The following codes identify payees that are exempt from reporting under FATCA. These codes apply to persons submitting this form for accounts maintained outside of the United States by certain foreign financial institutions. Therefore, if you are only submitting this form for an account you hold in the United States, you may leave this field blank. Consult with the person requesting this form if you are uncertain if the financial institution is subject to these requirements. A requester may indicate that a code is not required by providing you with a Form W-9 with "Not Applicable" (or any similar indication) written or printed on the line for a FATCA exemption code.

A—An organization exempt from tax under section 501(a) or any individual retirement plan as defined in section 7701(a)(37)

B—The United States or any of its agencies or instrumentalities

C—A state, the District of Columbia, a U.S. commonwealth or possession, or any of their political subdivisions or instrumentalities

D—A corporation the stock of which is regularly traded on one or more established securities markets, as described in Regulations section 1.1472-1(c)(1)(i)

E—A corporation that is a member of the same expanded affiliated group as a corporation described in Regulations section 1.1472-1(c)(1)(i)

F—A dealer in securities, commodities, or derivative financial instruments (including notional principal contracts, futures, forwards, and options) that is registered as such under the laws of the United States or any state

G—A real estate investment trust

H—A regulated investment company as defined in section 851 or an entity registered at all times during the tax year under the Investment Company Act of 1940

I—A common trust fund as defined in section 584(a)

J—A bank as defined in section 581

K—A broker

L—A trust exempt from tax under section 664 or described in section 4947(a)(1)

M—A tax exempt trust under a section 403(b) plan or section 457(g) plan

Note: You may wish to consult with the financial institution requesting this form to determine whether the FATCA code and/or exempt payee code should be completed.

Line 5

Enter your address (number, street, and apartment or suite number). This is where the requester of this Form W-9 will mail your information returns. If this address differs from the one the requester already has on file, write NEW at the top. If a new address is provided, there is still a chance the old address will be used until the payor changes your address in their records.

Line 6

Enter your city, state, and ZIP code.

Part I. Taxpayer Identification Number (TIN)

Enter your TIN in the appropriate box. If you are a resident alien and you do not have and are not eligible to get an SSN, your TIN is your IRS individual taxpayer identification number (ITIN). Enter it in the social security number box. If you do not have an ITIN, see *How to get a TIN* below.

If you are a sole proprietor and you have an EIN, you may enter either your SSN or EIN.

If you are a single-member LLC that is disregarded as an entity separate from its owner, enter the owner's SSN (or EIN, if the owner has one). Do not enter the disregarded entity's EIN. If the LLC is classified as a corporation or partnership, enter the entity's EIN.

Note: See *What Name and Number To Give the Requester*, later, for further clarification of name and TIN combinations.

How to get a TIN. If you do not have a TIN, apply for one immediately. To apply for an SSN, get Form SS-5, Application for a Social Security Card, from your local SSA office or get this form online at www.SSA.gov. You may also get this form by calling 1-800-772-1213. Use Form W-7, Application for IRS Individual Taxpayer Identification Number, to apply for an ITIN, or Form SS-4, Application for Employer Identification Number, to apply for an EIN. You can apply for an EIN online by accessing the IRS website at www.irs.gov/Businesses and clicking on Employer Identification Number (EIN) under Starting a Business. Go to www.irs.gov/Forms to view, download, or print Form W-7 and/or Form SS-4. Or, you can go to www.irs.gov/OrderForms to place an order and have Form W-7 and/or SS-4 mailed to you within 10 business days.

If you are asked to complete Form W-9 but do not have a TIN, apply for a TIN and write "Applied For" in the space for the TIN, sign and date the form, and give it to the requester. For interest and dividend payments, and certain payments made with respect to readily tradable instruments, generally you will have 60 days to get a TIN and give it to the requester before you are subject to backup withholding on payments. The 60-day rule does not apply to other types of payments. You will be subject to backup withholding on all such payments until you provide your TIN to the requester.

Note: Entering "Applied For" means that you have already applied for a TIN or that you intend to apply for one soon.

Caution: A disregarded U.S. entity that has a foreign owner must use the appropriate Form W-8.

Part II. Certification

To establish to the withholding agent that you are a U.S. person, or resident alien, sign Form W-9. You may be requested to sign by the withholding agent even if item 1, 4, or 5 below indicates otherwise.

For a joint account, only the person whose TIN is shown in Part I should sign (when required). In the case of a disregarded entity, the person identified on line 1 must sign. Exempt payees, see *Exempt payee code*, earlier.

Signature requirements. Complete the certification as indicated in items 1 through 5 below.

1. Interest, dividend, and barter exchange accounts opened before 1984 and broker accounts considered active during 1983.

You must give your correct TIN, but you do not have to sign the certification.

2. Interest, dividend, broker, and barter exchange accounts opened after 1983 and broker accounts considered inactive during 1983. You must sign the certification or backup withholding will apply. If you are subject to backup withholding and you are merely providing your correct TIN to the requester, you must cross out item 2 in the certification before signing the form.

3. Real estate transactions. You must sign the certification. You may cross out item 2 of the certification.

4. Other payments. You must give your correct TIN, but you do not have to sign the certification unless you have been notified that you have previously given an incorrect TIN. "Other payments" include payments made in the course of the requester's trade or business for rents, royalties, goods (other than bills for merchandise), medical and health care services (including payments to corporations), payments to a nonemployee for services, payments made in settlement of payment card and third party network transactions, payments to certain fishing boat crew members and fishermen, and gross proceeds paid to attorneys (including payments to corporations).

5. Mortgage interest paid by you, acquisition or abandonment of secured property, cancellation of debt, qualified tuition program payments (under section 529), ABLE accounts (under section 529A), IRA, Coverdell ESA, Archer MSA or HSA contributions or distributions, and pension distributions. You must give your correct TIN, but you do not have to sign the certification.

What Name and Number To Give the Requester

For this type of account:	Give name and SSN of:
1. Individual	The individual
2. Two or more individuals (joint account) other than an account maintained by an FFI	The actual owner of the account or, if combined funds, the first individual on the account ¹
3. Two or more U.S. persons (joint account maintained by an FFI)	Each holder of the account
4. Custodial account of a minor (Uniform Gift to Minors Act)	The minor ²
5. a. The usual revocable savings trust (grantor is also trustee)	The grantor-trustee ¹
b. So-called trust account that is not a legal or valid trust under state law	The actual owner ¹
6. Sole proprietorship or disregarded entity owned by an individual	The owner ³
7. Grantor trust filing under Optional Form 1099 Filing Method 1 (see Regulations section 1.671-4(b)(2)(i)(A))	The grantor*

For this type of account:	Give name and EIN of:
8. Disregarded entity not owned by an individual	The owner
9. A valid trust, estate, or pension trust	Legal entity ⁴
10. Corporation or LLC electing corporate status on Form 8832 or Form 2553	The corporation
11. Association, club, religious, charitable, educational, or other tax-exempt organization	The organization
12. Partnership or multi-member LLC	The partnership
13. A broker or registered nominee	The broker or nominee

For this type of account:	Give name and EIN of:
14. Account with the Department of Agriculture in the name of a public entity (such as a state or local government, school district, or prison) that receives agricultural program payments	The public entity
15. Grantor trust filing under the Form 1041 Filing Method or the Optional Form 1099 Filing Method 2 (see Regulations section 1.671-4(b)(2)(i)(B))	The trust

¹ List first and circle the name of the person whose number you furnish. If only one person on a joint account has an SSN, that person's number must be furnished.

² Circle the minor's name and furnish the minor's SSN.

³ You must show your individual name and you may also enter your business or DBA name on the "Business name/disregarded entity" name line. You may use either your SSN or EIN (if you have one), but the IRS encourages you to use your SSN.

⁴ List first and circle the name of the trust, estate, or pension trust. (Do not furnish the TIN of the personal representative or trustee unless the legal entity itself is not designated in the account title.) Also see *Special rules for partnerships*, earlier.

*Note: The grantor also must provide a Form W-9 to trustee of trust.

Note: If no name is circled when more than one name is listed, the number will be considered to be that of the first name listed.

Secure Your Tax Records From Identity Theft

Identity theft occurs when someone uses your personal information such as your name, SSN, or other identifying information, without your permission, to commit fraud or other crimes. An identity thief may use your SSN to get a job or may file a tax return using your SSN to receive a refund.

To reduce your risk:

- Protect your SSN,
- Ensure your employer is protecting your SSN, and
- Be careful when choosing a tax preparer.

If your tax records are affected by identity theft and you receive a notice from the IRS, respond right away to the name and phone number printed on the IRS notice or letter.

If your tax records are not currently affected by identity theft but you think you are at risk due to a lost or stolen purse or wallet, questionable credit card activity or credit report, contact the IRS Identity Theft Hotline at 1-800-908-4490 or submit Form 14039.

For more information, see Pub. 5027, Identity Theft Information for Taxpayers.

Victims of identity theft who are experiencing economic harm or a systemic problem, or are seeking help in resolving tax problems that have not been resolved through normal channels, may be eligible for Taxpayer Advocate Service (TAS) assistance. You can reach TAS by calling the TAS toll-free case intake line at 1-877-777-4778 or TTY/TDD 1-800-829-4059.

Protect yourself from suspicious emails or phishing schemes. Phishing is the creation and use of email and websites designed to mimic legitimate business emails and websites. The most common act is sending an email to a user falsely claiming to be an established legitimate enterprise in an attempt to scam the user into surrendering private information that will be used for identity theft.

The IRS does not initiate contacts with taxpayers via emails. Also, the IRS does not request personal detailed information through email or ask taxpayers for the PIN numbers, passwords, or similar secret access information for their credit card, bank, or other financial accounts.

If you receive an unsolicited email claiming to be from the IRS, forward this message to phishing@irs.gov. You may also report misuse of the IRS name, logo, or other IRS property to the Treasury Inspector General for Tax Administration (TIGTA) at 1-800-366-4484. You can forward suspicious emails to the Federal Trade Commission at spam@uce.gov or report them at www.ftc.gov/complaint. You can contact the FTC at www.ftc.gov/idtheft or 877-IDTHEFT (877-438-4338). If you have been the victim of identity theft, see www.IdentityTheft.gov and Pub. 5027.

Visit www.irs.gov/IdentityTheft to learn more about identity theft and how to reduce your risk.

Privacy Act Notice

Section 6109 of the Internal Revenue Code requires you to provide your correct TIN to persons (including federal agencies) who are required to file information returns with the IRS to report interest, dividends, or certain other income paid to you; mortgage interest you paid; the acquisition or abandonment of secured property; the cancellation of debt; or contributions you made to an IRA, Archer MSA, or HSA. The person collecting this form uses the information on the form to file information returns with the IRS, reporting the above information. Routine uses of this information include giving it to the Department of Justice for civil and criminal litigation and to cities, states, the District of Columbia, and U.S. commonwealths and possessions for use in administering their laws. The information also may be disclosed to other countries under a treaty, to federal and state agencies to enforce civil and criminal laws, or to federal law enforcement and intelligence agencies to combat terrorism. You must provide your TIN whether or not you are required to file a tax return. Under section 3406, payers must generally withhold a percentage of taxable interest, dividend, and certain other payments to a payee who does not give a TIN to the payer. Certain penalties may also apply for providing false or fraudulent information.

REFERENCES

All bidders must provide three (3) projects of a similar nature as being performed in the immediate past five (5) years with the name, address and telephone number of the contact person having knowledge of the project or three (3) references (name, address, and telephone number) with knowledge of the integrity and business practices of the contractor.

PROJECT	
FIRM	
ADDRESS	
CONTACT	
TELEPHONE	

PROJECT	
FIRM	
ADDRESS	
CONTACT	
TELEPHONE	

PROJECT	
FIRM	
ADDRESS	
CONTACT	
TELEPHONE	



Bureau of Construction
2300 South Dirksen Parkway/Room 322
Springfield, IL 62764

Instructions: Complete this form by either typing or using black ink. "Authorization to Bid" will not be issued unless both sides of this form are completed in detail. Use additional forms as needed to list all work.

Part I. Work Under Contract

List below all work you have under contract as either a prime contractor or a subcontractor. It is required to include all pending low bids not yet awarded or rejected. In a joint venture, list only that portion of the work which is the responsibility of your company. The uncompleted dollar value is to be based upon the most recent engineer's or owners estimate, and must include work subcontracted to others. If no work is contracted, show NONE.

	1	2	3	4	Awards Pending	Accumulated Totals
Contract Number						
Contract With						
Estimated Completion Date						
Total Contract Price						
Uncompleted Dollar Value if Firm is the Prime Contractor						
Uncompleted Dollar Value if Firm is the Subcontractor						
Total Value of All Work						

Part II. Awards Pending and Uncompleted Work to be done with your own forces.

List below the uncompleted dollar value of work for each contract and awards pending to be completed with your own forces. All work subcontracted to others will be listed on the reverse of this form. In a joint venture, list only that portion of the work to be done by your company. If no work is contracted, show NONE.

Earthwork						
Portland Cement Concrete Paving						
HMA Plant Mix						
HMA Paving						
Clean & Seal Cracks/Joints						
Aggregate Bases, Surfaces						
Highway, R.R., Waterway Struc.						
Drainage						
Electrical						
Cover and Seal Coats						
Concrete Construction						
Landscaping						
Fencing						
Guardrail						
Painting						
Signing						
Cold Milling, Planning, Rotomilling						
Demolition						
Pavement Markings (Paint)						
Other Construction (List)						
Totals						

Disclosure of this information is REQUIRED to accomplish the statutory purpose as outlined in the "Illinois Procurement Code." Failure to comply will result in non-issuance of an "Authorization To Bid." This form has been approved by the State Forms Management Center.

Part III. Work Subcontracted to Others.

For each contract described in Part I, list all the work you have subcontracted to others.

	1	2	3	4	Awards Pending
Subcontractor					
Type of Work					
Subcontract Price					
Amount Uncompleted					
Subcontractor					
Type of Work					
Subcontract Price					
Amount Uncompleted					
Subcontractor					
Type of Work					
Subcontract Price					
Amount Uncompleted					
Subcontractor					
Type of Work					
Subcontract Price					
Amount Uncompleted					
Subcontractor					
Type of Work					
Subcontract Price					
Amount Uncompleted					
Total Uncompleted					

Notary

I, being duly sworn, do hereby declare this affidavit is a true and correct statement relating to ALL uncompleted contracts of the undersigned for Federal, State, County, City and private work, including ALL subcontract work, ALL pending low bids not yet awarded or rejected and ALL estimated completion dates.

Officer or Director

Title

Signature

Date

Company

Address

City

State

Zip Code

Subscribed and sworn to before me

this _____ day of _____, _____

(Signature of Notary Public)

My commission expires _____

(Notary Seal)

Add pages for additional contracts

TABLE OF CONTENTS

PROPOSAL DOCUMENTS

- a. Local Public Agency Formal Contract Proposal (BLR 12200)
- b. Schedule of Prices (BLR 12201)
- c. Proposal Bid Bond (BLR 12230)
- d. DuPage County Apprenticeship or Training Program Certification
- e. Affidavit of Illinois Business Office (BLR 12326)
- f. DuPage County – Vendor Ethics Disclosure Statement
- g. IRS Form W-9
- h. Three (3) References
- i. Affidavit of Availability (BC 57)

PLANS.....1-20

Location Exhibits	2-7
Summary of Quantities	8
Typical Details	9-11
Details & Standards	12-20

SPECIAL PROVISIONS21-38

Index for Supplemental Specifications and Recurring Special Provisions.....	22
Check Sheet for Recurring Special Provisions.....	23
Local Roads & Street Recurring Special Provisions.....	24
Bidding Requirements and Conditions for Contract Proposals.....	25-26
Scope of Work	26
Public Convenience & Safety (Article 107.09).....	26-28
Prosecution and Progress (Section 108)	28
Measurement and Payment (Section 109)	28
Mobilization (Section 671).....	28
Traffic Control	28-30
Protection & Restoration of Property (Article 107.20).....	30
Prosecution of the Work (Section 108)	30
Notification to Engineer (Article 108.02).....	30-31
Scheduling of Work (Article 108.02).....	31
Protection of Existing Plant Material (Article 201.05)	31
Bituminous Material – Tack Coat (Article 406.05).....	31-32
HMA Asphalt (D-1)	33
Friction Aggregate (D-1)	34-36
HMA Mixture Design V (D-1)	37-38
Aggregate Shoulders Ty B (Section 481)	38
Completion & Final Punchlist	38
Payment Estimates	38

DUPAGE COUNTY PREVAILING WAGE39-45

BDE SPECIAL PROVISIONS.....46-54

BDE 80384 – Compensable Delay Costs..... 46-49

BDE 80261 – Construction Air Quality – Diesel Retrofit..... 50-52

BDE 80442 – Hot-Mix Asphalt53

BDE 80391 – Subcontractor Mobilization Payments..... 54

BDE 80439 – Vehicle and Equipment Warning Lights55

PLANS

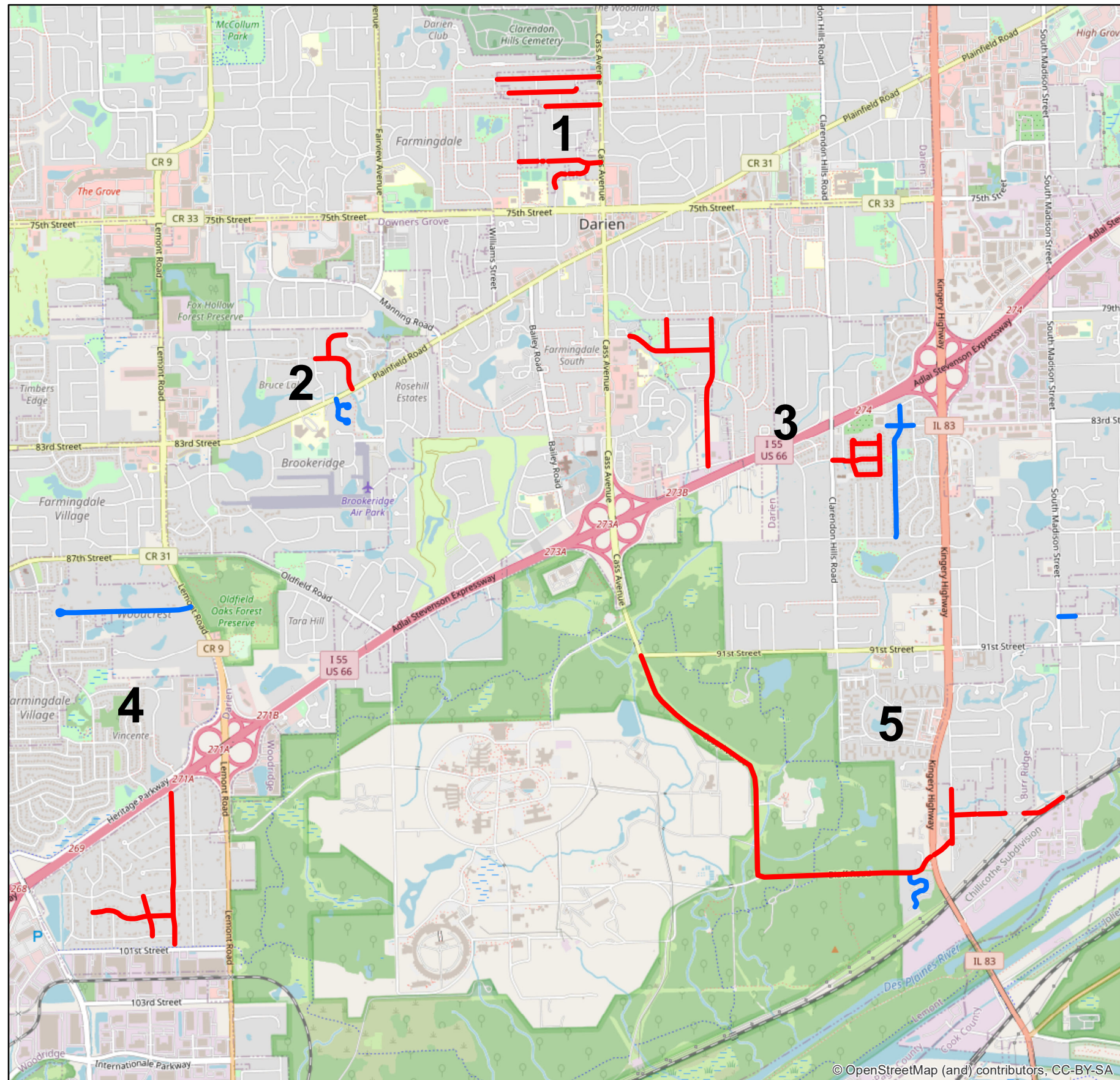



LOCATION EXHIBIT

DOWNERS GROVE TOWNSHIP 2022 ROADS PROGRAM

SECTION: 22-03000-01-GM

**PREPARED FOR:
DOWNERS GROVE TOWNSHIP ROADS DISTRICT
LAWRENCE C. ANDERSON - HIGHWAY COMMISSIONER
DELIVERY DATE 6/27/2022**

Legend

-  Patching
-  Resurfacing

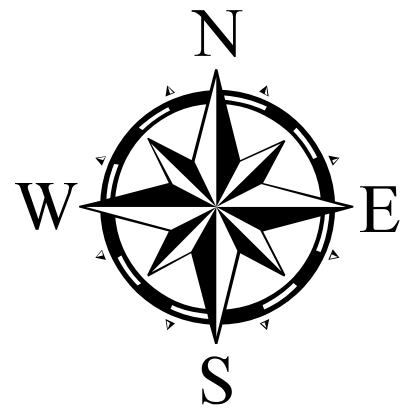

THERE IS NO WORK IN THE IDOT R.O.W ALL SIDEWALKS MEET ADA COMPLIANCE

© OpenStreetMap (and) contributors, CC-BY-SA



LOCATION EXHIBIT

DOWNERS GROVE TOWNSHIP 2022 ROADS PROGRAM

SECTION: 22-03000-01-GM

SECTION 1

PREPARED FOR:
DOWNERS GROVE TOWNSHIP ROADS DISTRICT
LAWRENCE C. ANDERSON - HIGHWAY COMMISSIONER
DELIVERY DATE 6/27/2022

Legend

- Patching
- Resurfacing

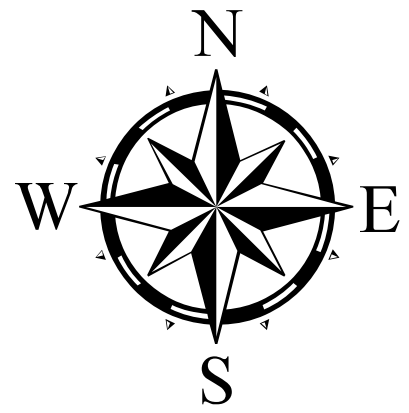

THERE IS NO WORK IN THE IDOT R.O.W ALL SIDEWALKS MEET ADA COMPLIANCE

© OpenStreetMap (and) contributors, CC-BY-SA



LOCATION EXHIBIT



DOWNERS GROVE TOWNSHIP 2022 ROADS PROGRAM

SECTION: 22-03000-01-GM

SECTION 2

**PREPARED FOR:
DOWNERS GROVE TOWNSHIP ROADS DISTRICT
LAWRENCE C. ANDERSON - HIGHWAY COMMISSIONER
DELIVERY DATE 6/27/2022**

Legend

-  Patching
-  Resurfacing

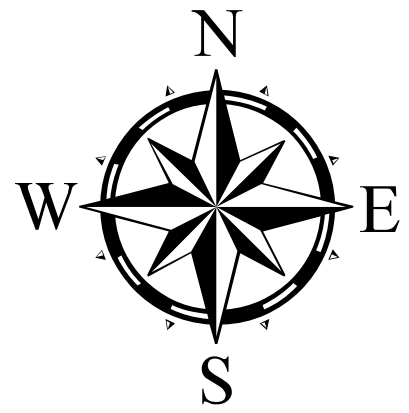

THERE IS NO WORK IN THE IDOT R.O.W ALL SIDEWALKS MEET ADA COMPLIANCE

© OpenStreetMap (and) contributors, CC-BY-SA

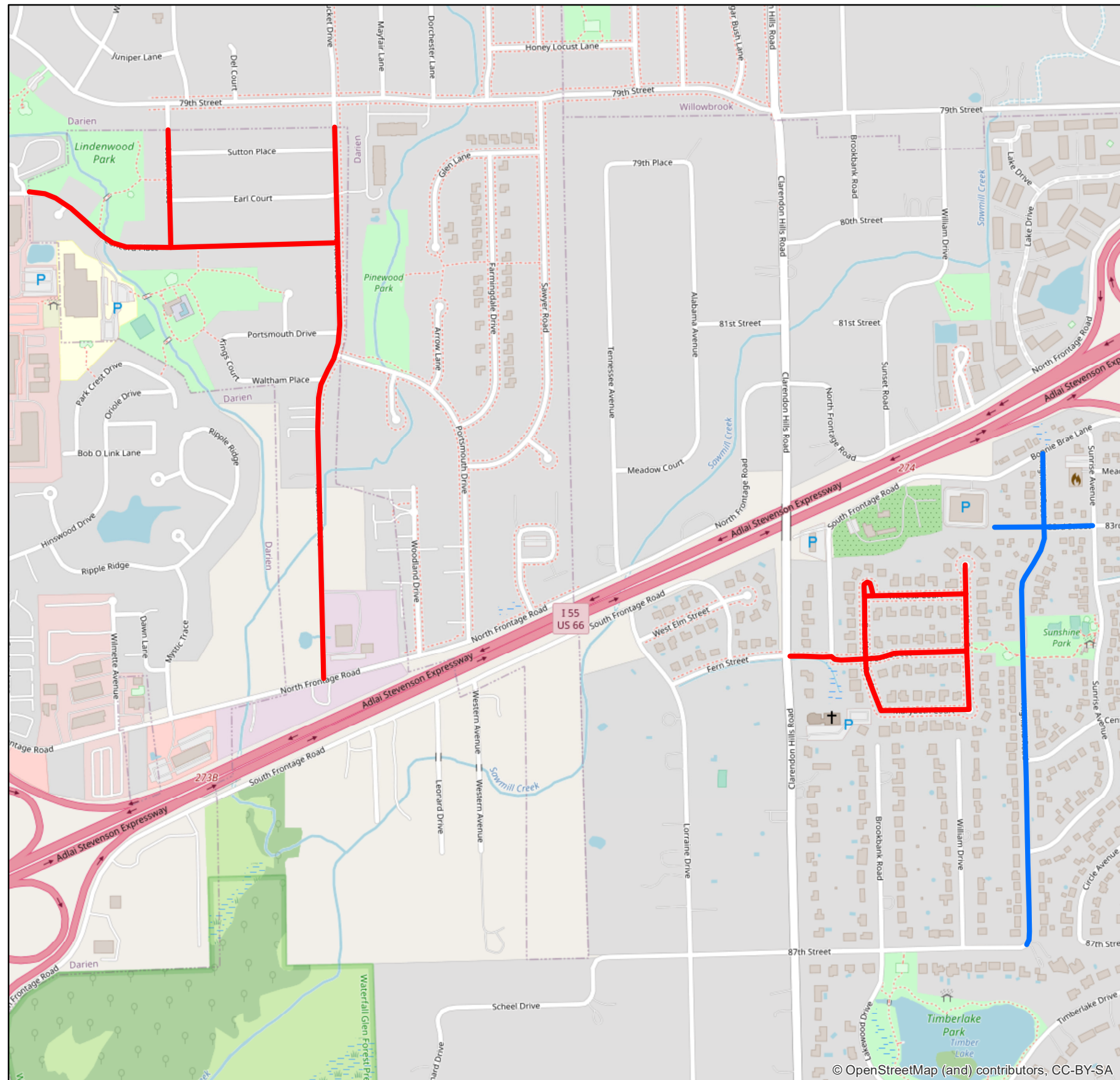

LOCATION EXHIBIT

DOWNERS GROVE TOWNSHIP 2022 ROADS PROGRAM

SECTION: 22-03000-01-GM

SECTION 3

**PREPARED FOR:
DOWNERS GROVE TOWNSHIP ROADS DISTRICT
LAWRENCE C. ANDERSON - HIGHWAY COMMISSIONER
DELIVERY DATE 6/27/2022**

Legend

- Patching
- Resurfacing

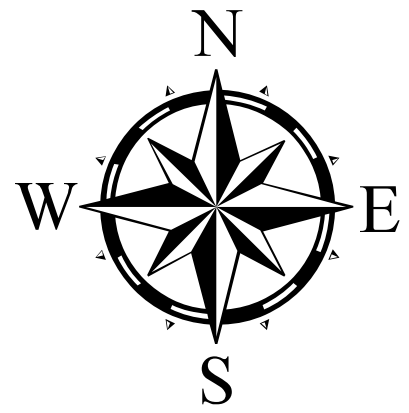

THERE IS NO WORK IN THE IDOT R.O.W ALL SIDEWALKS MEET ADA COMPLIANCE

© OpenStreetMap (and) contributors, CC-BY-SA

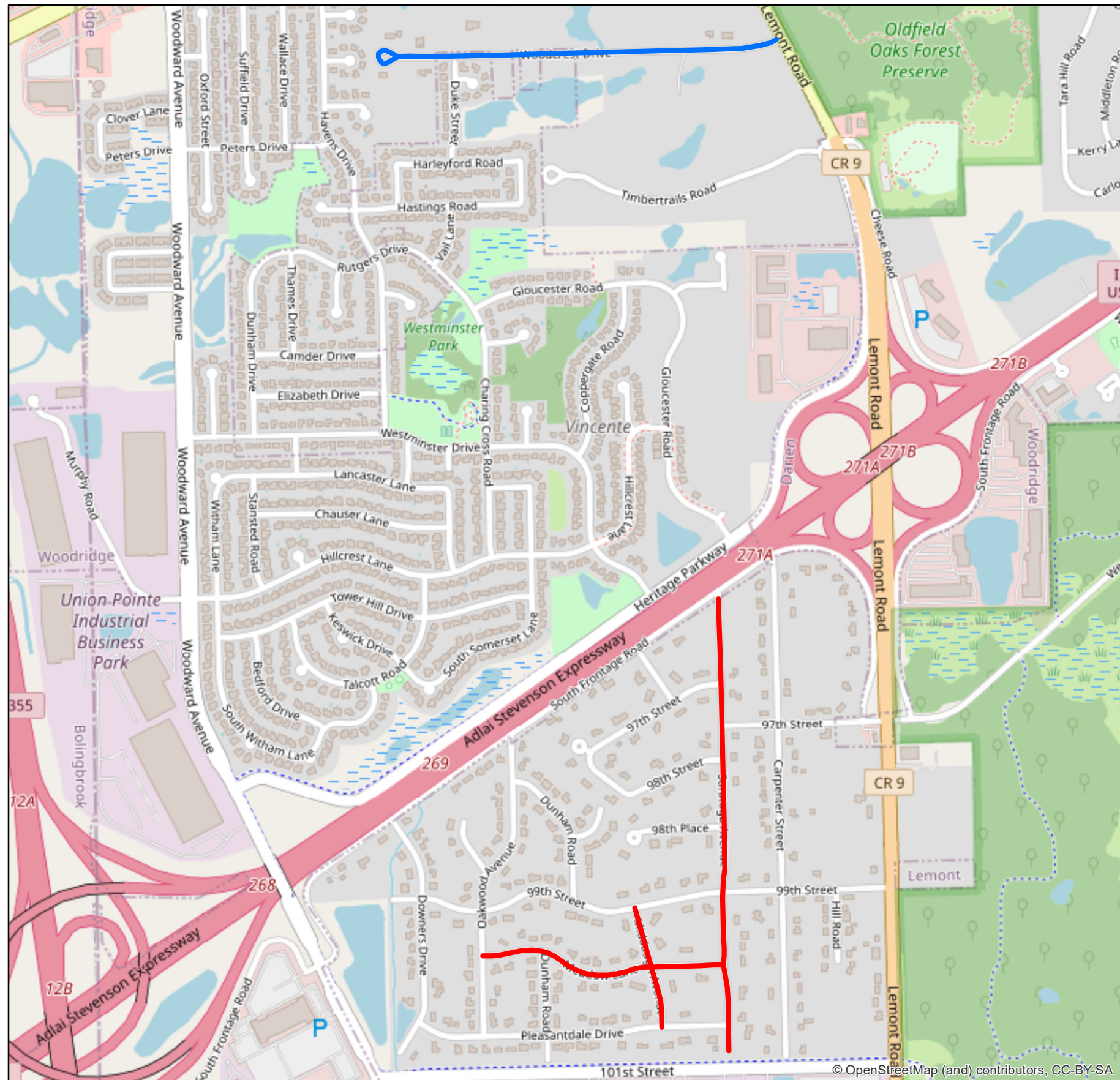

LOCATION EXHIBIT

DOWNERS GROVE TOWNSHIP 2022 ROADS PROGRAM

SECTION: 22-03000-01-GM

SECTION 4

PREPARED FOR:
DOWNERS GROVE TOWNSHIP ROADS DISTRICT
LAWRENCE C. ANDERSON - HIGHWAY COMMISSIONER
DELIVERY DATE 6/27/2022

Legend

- Patching
- Resurfacing

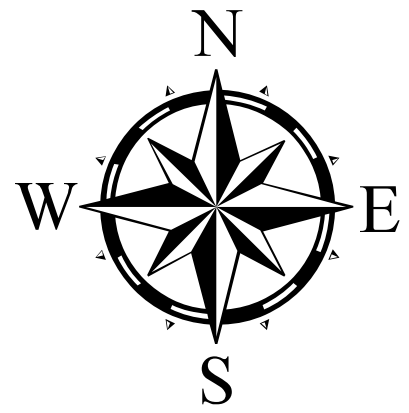

THERE IS NO WORK IN THE IDOT R.O.W ALL SIDEWALKS MEET ADA COMPLIANCE

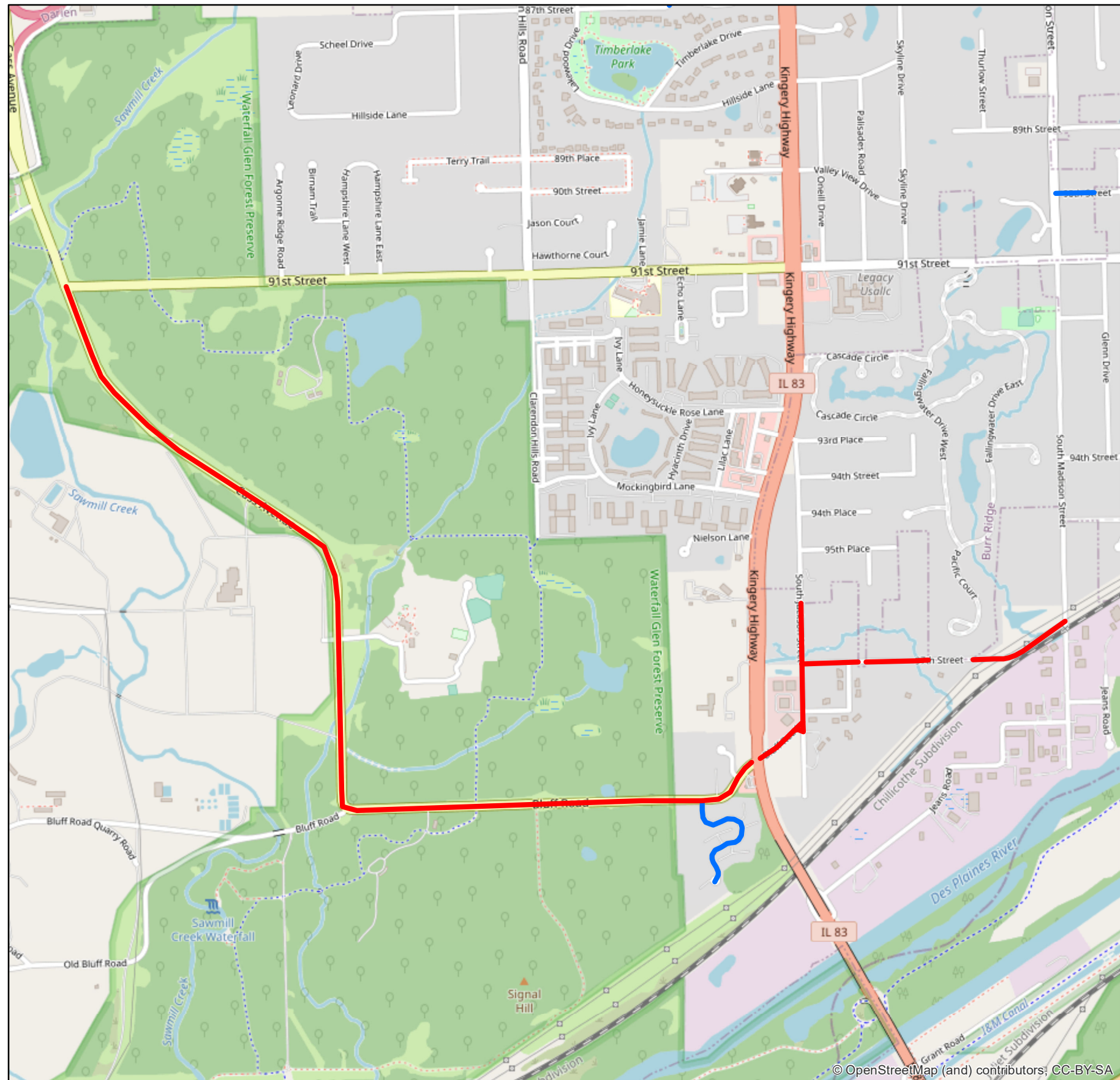

LOCATION EXHIBIT

DOWNERS GROVE TOWNSHIP 2022 ROADS PROGRAM

SECTION: 22-03000-01-GM

SECTION 5

**PREPARED FOR:
DOWNERS GROVE TOWNSHIP ROADS DISTRICT
LAWRENCE C. ANDERSON - HIGHWAY COMMISSIONER
DELIVERY DATE 6/27/2022**

Legend

- Patching
- Resurfacing

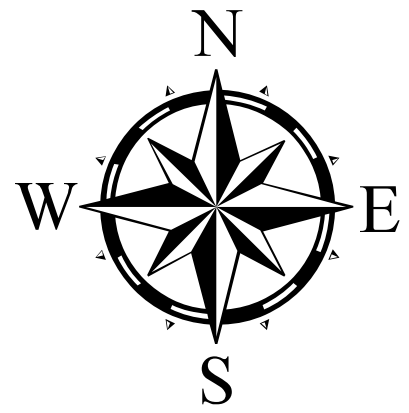

THERE IS NO WORK IN THE IDOT R.O.W ALL SIDEWALKS MEET ADA COMPLIANCE

© OpenStreetMap (and) contributors, CC-BY-SA

TYPICAL DETAILS

HMA MIXTURE REQUIREMENTS	
MIXTURE TYPE	AIR VOIDS
PAVEMENT RESURFACING	
HMA SURFACE COURSE, MIX "D", N50, (IL-9.5mm)	4% @ 50 GYR.
LEVELING BINDER (MACHING METHOD), IL-9.5, N50	4% @ 50 GYR.

THE UNIT WEIGHT USED TO CALCULATE ALL HMA SURFACE MIXTURE QUANTITIES IS 112 LBS/SQ YD/INCH
 THE "AC TYPE" FOR POLYMERIZED HMA MIXES SHALL BE "SBS/SBR PG 76 - 22" AND FOR NON-POLYMERIZED HMA
 THE "AC TYPE" SHALL BE "PG 64 - 22" UNLESS MODIFIED BY DISTRICT ONE SPECIAL PROVISIONS.
 FOR USE OF RECYCLED MATERIALS SEE SPECIAL PROVISIONS.

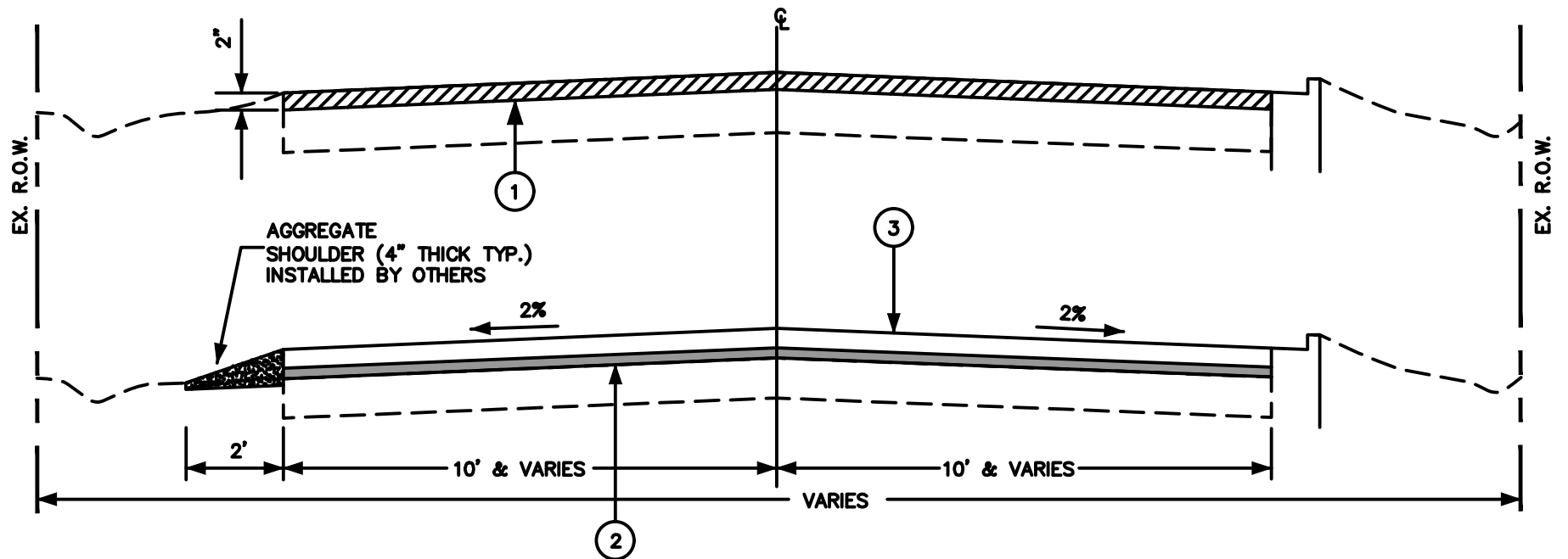

LEGEND:

- ① HMA SURFACE REMOVAL, 2"
- ② POLYMERIZED LEVELING BINDER (MACHINE METHOD), IL-4.75, N50, 0.75"
- ③ HMA SURFACE COURSE, MIX "D", IL-9.5, N50, 1.5"

TYPICAL SECTION – SURFACE REMOVAL & RESURFACE

N.T.S.



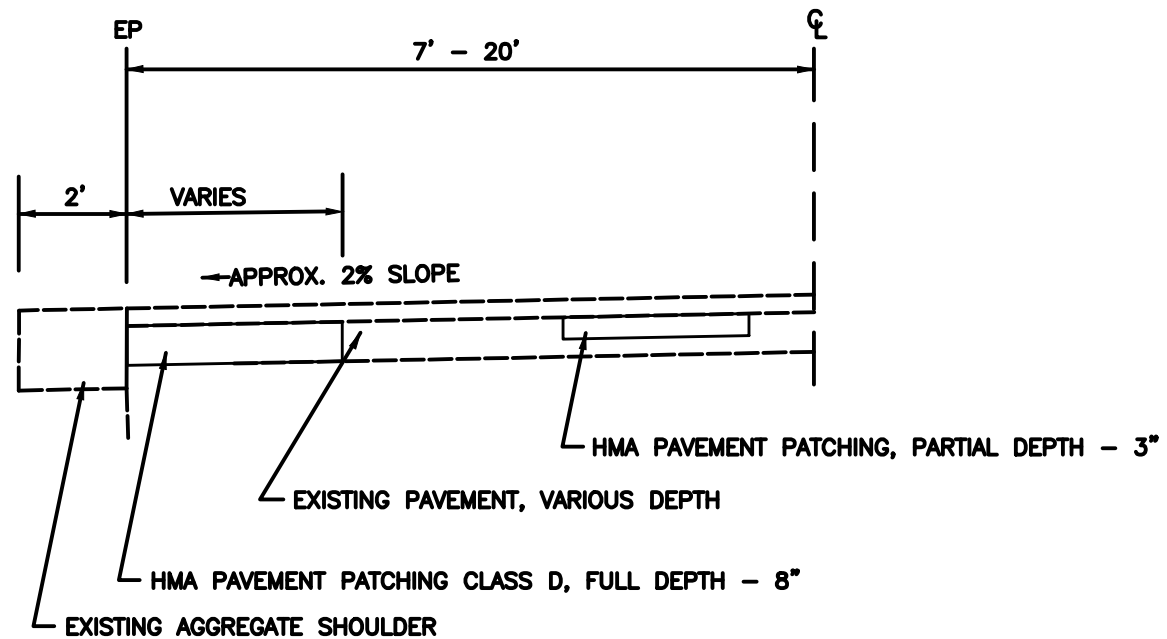

TYPICAL SECTION - PATCHING
N.T.S.

**DETAIL
&
STANDARDS**

CLASS C

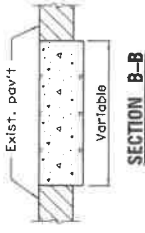
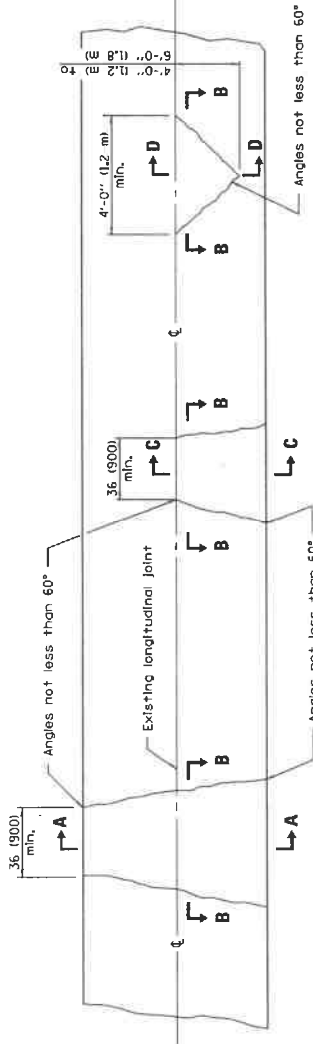

SECTION A-A

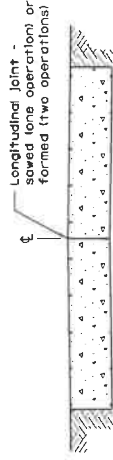

SECTION C-C

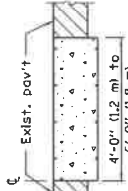

DETAIL OF SAWED CONTRACTION JOINT

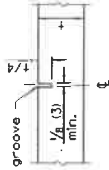

NOTE:
Longitudinal joints shall be as detailed on Standard 420001, except tie bars are not required for patches 20'-0" (6.0 m) or less in length.

CLASS D

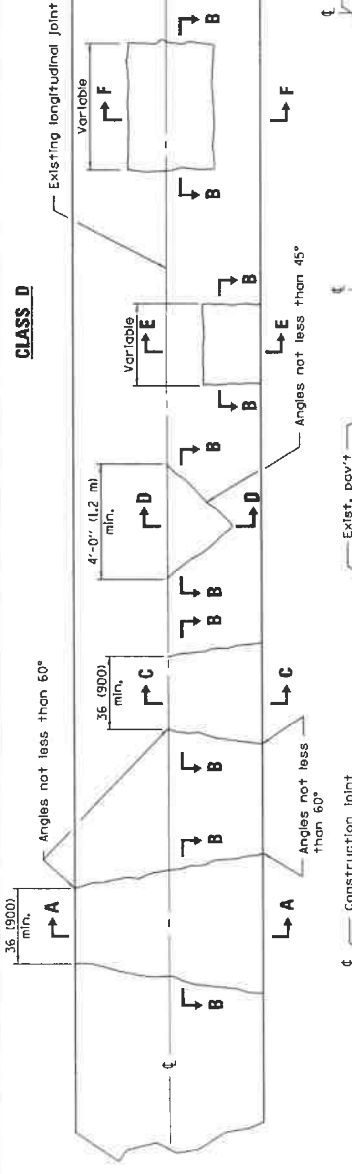

SECTION B-B

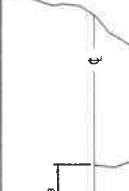
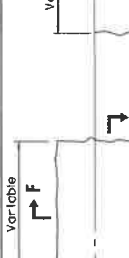

SECTION E-E

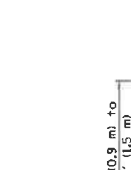
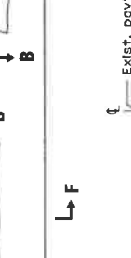

SECTION A-A
(Built in two operations)

SECTION B-B

SECTION C-C

SECTION D-D

SECTION E-E

GENERAL NOTES
Existing tie bars shall be either cut or removed.
Marginal bars shall be cut.
All dimensions are in inches (millimeters) unless otherwise shown.

Illinois Department of Transportation
PASSED January 1, 2008
ENGINEER OF POLICY AND PROCEDURES
APPROVED [Signature] JUNE 11, 2008
ENGINEER OF DESIGN AND ENVIRONMENT

DATE	REVISIONS
1-1-08	Switched units to English (metric).
1-1-07	Revised Note for Class C patches.

CLASS C and D PATCHES

STANDARD 442201-03

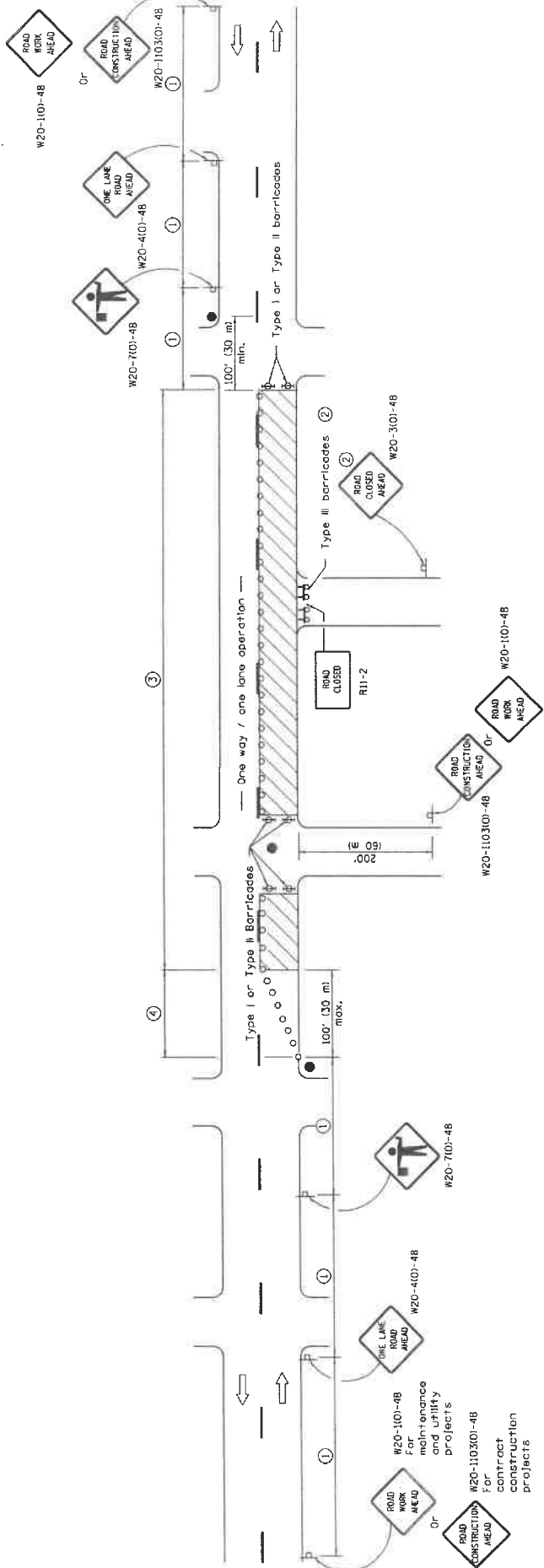

SIGN SPACING	
Posted Speed	Sign Spacing
55	500' (150 m)
50-45	350' (100 m)
<45	200' (60 m)

SYMBOLS

- Work area
- Cone, drum or barricade (not required for moving operations)
- Sign on portable or permanent support
- Flagger with traffic control sign
- Barricade or drum with flashing light
- Type III barricade with flashing lights

- ① Refer to SIGN SPACING TABLE for distances.
- ② For approved sideroad closures.
- ③ Cones at 25' (8 m) centers for 250' (75 m). Additional cones may be placed at 30' (9 m) centers. Type II barricades are used. The interval between devices may be doubled.
- ④ Cones, drums or barricades at 20' (6 m) centers.

GENERAL NOTES

This Standard is used where at any time, day or night, any vehicle, equipment, workers or their activities encroach on the pavement requiring the closure of one traffic lane in an urban area. All dimensions are in inches (millimeters) unless otherwise shown.

Illinois Department of Transportation

APPROVED: *[Signature]* 2011
 ENGINEER OF SAFETY ENGINEERING

APPROVED: *[Signature]* 2011
 ENGINEER OF DESIGN AND ENVIRONMENT

ISSUED 1-1-97

DATE	REVISIONS
1-1-11	Revised flagger sign.
1-1-09	Switched units to English (metric).
	Corrected sign No.'s.

**URBAN LANE CLOSURE,
2L, 2W, UNDIVIDED**

STANDARD 701501-06

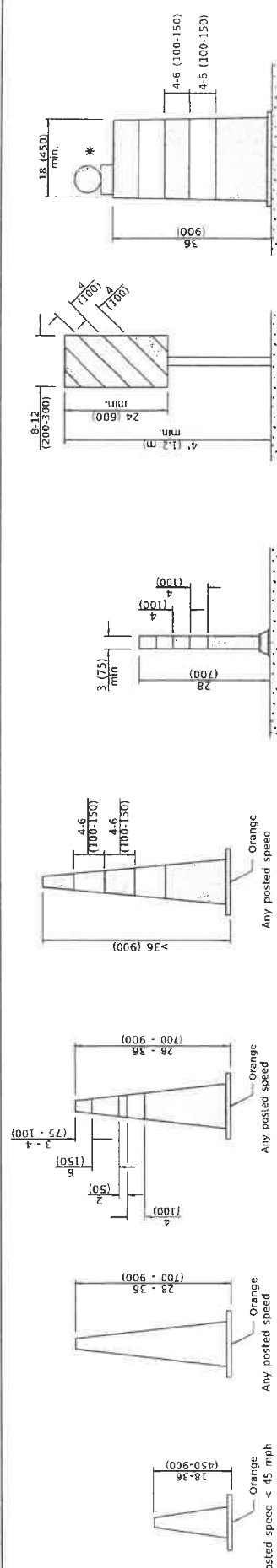

CONES

DAYTIME USE
Orange. Posted speed < 45 mph. 18-36 (450-900) min.

Orange. Any posted speed. 28-36 (700-900) min.

DAY OR NIGHTTIME USE
Orange. Any posted speed. 3-4 (75-100) min.

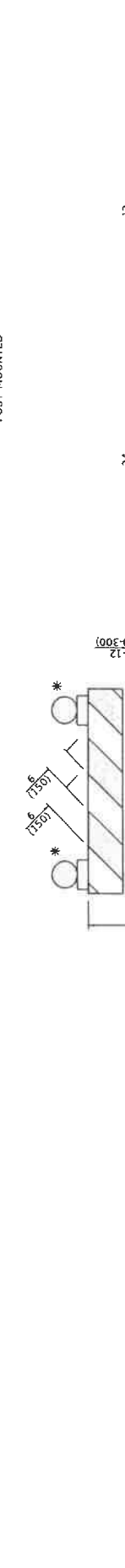

TUBULAR MARKER
3 (75) min. 2.8 (70) min.

VERTICAL PANEL POST MOUNTED
8-12 (200-300) min. 4 (100) min.

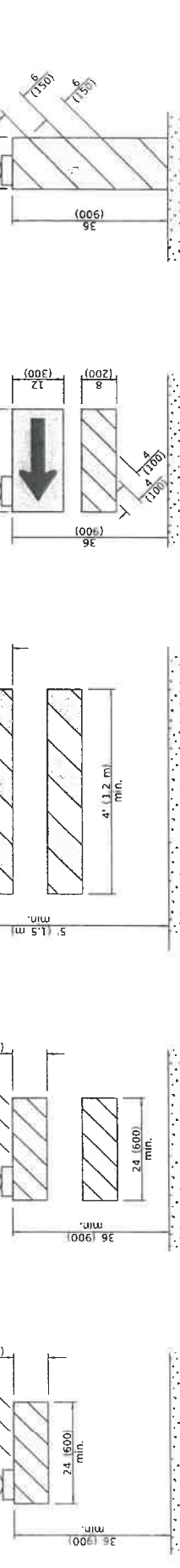

TYPE I BARRICADE
8-12 (200-300) min. 24 (600) min. 36 (900) min. 4 (100) min.

TYPE II BARRICADE
8-12 (200-300) min. 24 (600) min. 36 (900) min. 4 (100) min.



TYPE III BARRICADE
8-12 (200-300) min. 4' (1.2 m) min. 6 (150) min. 6 (150) min.



DETECTABLE PEDESTRIAN CHANNELIZING BARRICADE
8-12 (200-300) min. 36 (900) min. 6 (150) min. 6 (150) min.



DIRECTION INDICATOR BARRICADE
24 (600) min. 36 (900) min. 12 (300) min. 4 (100) min.



VERTICAL BARRICADE
12 (300) min. 36 (900) min. 6 (150) min. 6 (150) min.

DRUM
18-4500 min. 36 (900) min. 4-6 (100-150) min. 4-6 (100-150) min.

GENERAL NOTES

All heights shown shall be measured above the pavement surface.

All dimensions are in inches (millimeters) unless otherwise shown.

DATE	REVISIONS
1-1-19	Revised cone usage and added cones >36" (900 m) height.
1-1-18	Revised END WORK ZONE SPEED LIMIT sign from orange to white background.

TRAFFIC CONTROL DEVICES

STANDARD 701901-08

Sheet 1 of 3

Illinois Department of Transportation

APPROVED: [Signature] January 11, 2019

REGISTERED PROFESSIONAL ENGINEER IN SAFETY PROGRAMS AND ENGINEERING

APPROVED: [Signature] January 11, 2019

REGISTERED PROFESSIONAL ENGINEER IN SAFETY PROGRAMS AND ENGINEERING

ISSUED: 1-1-19

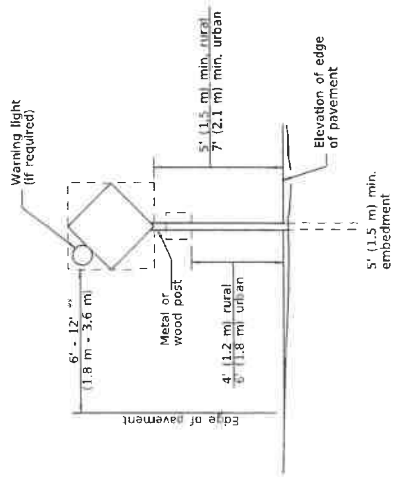

POST MOUNTED SIGNS

*: When curb or paved shoulder are present this dimension shall be 24 (600) to the face of curb or 6' (1.8 m) to the outside edge of the paved shoulder.

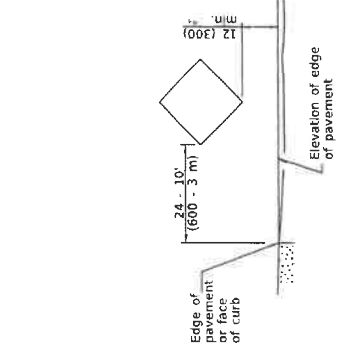

SIGNS ON TEMPORARY SUPPORTS

*** When work operations exceed four days, this dimension shall be 5' (1.5 m) min. If located behind the sign, the height shall be sufficient to be seen completely above the devices.

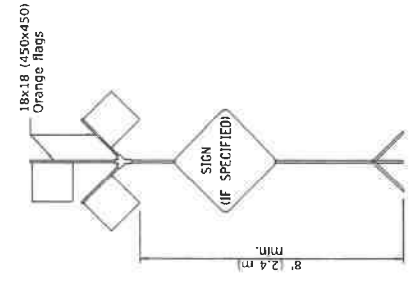

HIGH LEVEL WARNING DEVICE

ROAD CONSTRUCTION NEXT X MILES
G20-1104(10)-6036

END CONSTRUCTION
G20-1105(10)-6024

This signing is required for all projects 7 miles (3200 m) or more in length.
ROAD CONSTRUCTION NEXT X MILES sign shall be placed 500' (150 m) in advance of project limits.
END CONSTRUCTION sign shall be erected at the end of the job unless another job is within 2 miles (3200 m).
 Dual sign displays shall be utilized on multi-lane highways.

WORK LIMIT SIGNING

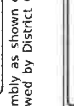
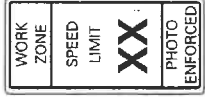

Sign assembly as shown on Standards or as allowed by District Operations.

This sign shall be used when the above sign assembly is used.

HIGHWAY CONSTRUCTION SPEED ZONE SIGNS

*** R10-1108p shall only be used along roadways under the jurisdiction of the State.

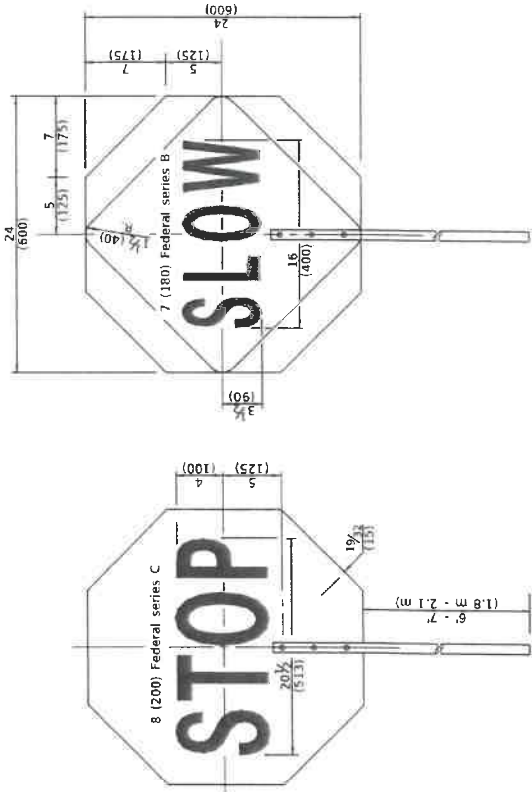

WIDTH RESTRICTION SIGN

XX:XX' width and X miles are variable.

TRAFFIC CONTROL DEVICES
STANDARD 701901-08
(Sheet 2 of 3)

FLAGGER TRAFFIC CONTROL SIGN

Illinois Department of Transportation
 Approved January 1, 2019
 ENGINEER OF SAFETY PROS. AND ENGINEERING
 APPROVED JANUARY 1, 2019
 ENGINEER OF DESIGN AND ENVIRONMENT

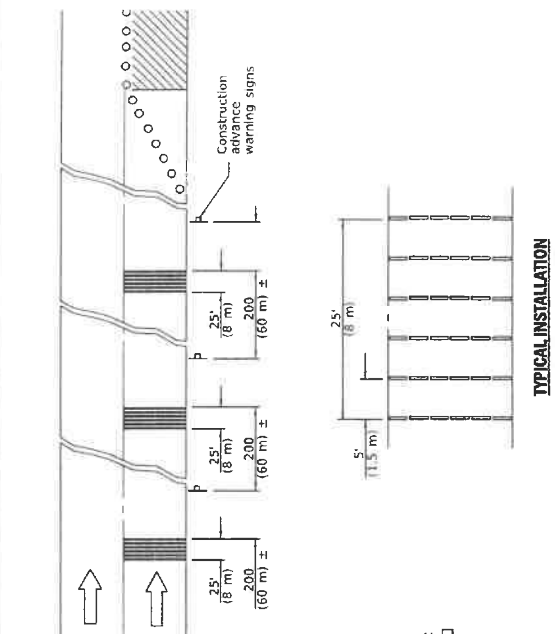

TYPICAL INSTALLATION

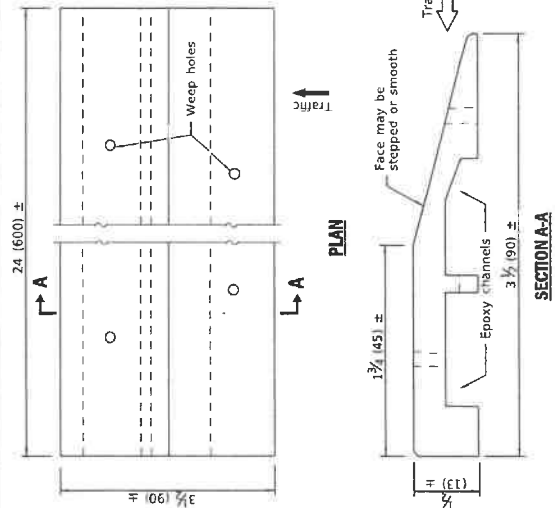

TEMPORARY RUMBLE STRIPS

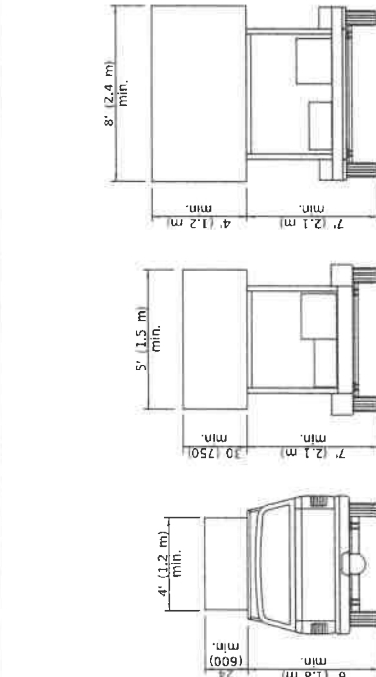

ARROW BOARDS

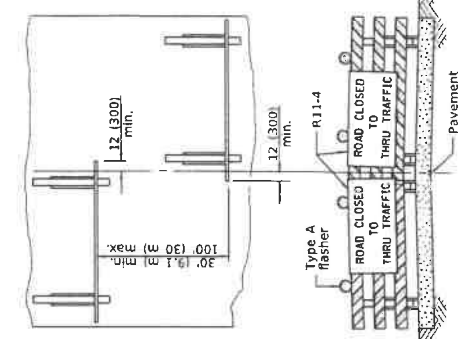

ROAD CLOSED TO THRU TRAFFIC
 ReflectORIZED striping shall appear on both sides of the barricades. If a Type III barricade with an attached sign panel which meets NCHRP 350 is not available, the signs may be mounted on temporary sign supports directly in front of the barricade.

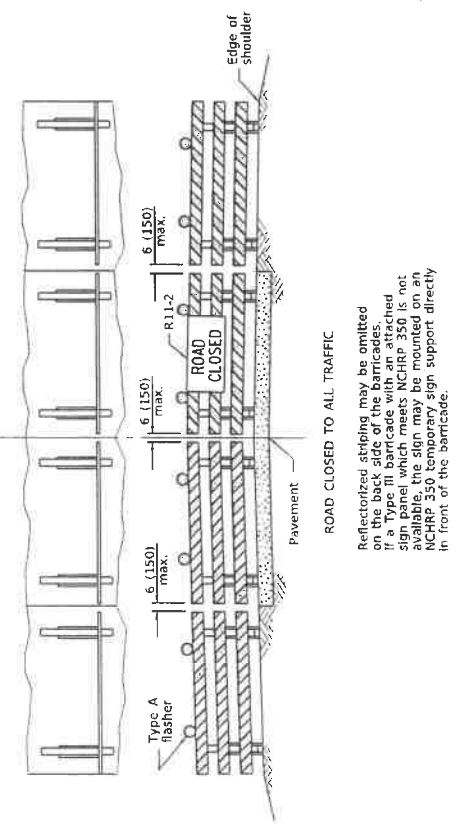

TYPICAL APPLICATIONS OF TYPE III BARRICADES CLOSING A ROAD
 ReflectORIZED striping may be omitted on the back side of the barricades. If a Type III barricade with an attached sign panel which meets NCHRP 350 is not available, the sign may be mounted on an NCHRP 350 temporary sign support directly in front of the barricade.

Illinois Department of Transportation
 APPROVED: [Signature] 2019
 ENGINEER OF SAFETY PRAC. AND ENGINEERING
 APPROVED: [Signature] 2019
 ENGINEER OF DESIGN AND ENVIRONMENT

ISSUED 1-1-13

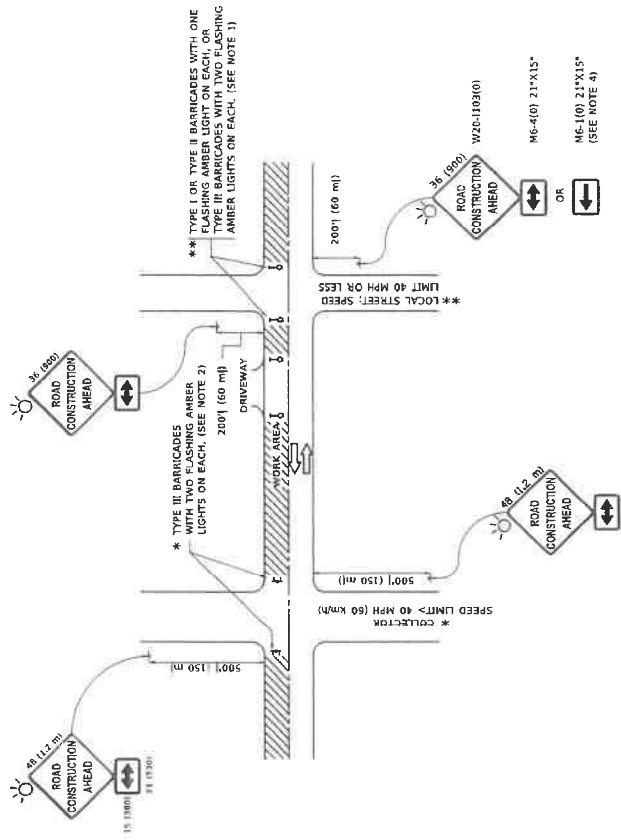

NOTES:

- SIDE ROAD WITH A SPEED LIMIT OF 40 MPH (60 km/h) OR LESS AS SHOWN ON THE DRAWING AND AS DIRECTED BY THE ENGINEER.
 - ONE "ROAD CONSTRUCTION AHEAD" SIGN 36 X 36 (900x900) WITH A FLASHER MOUNTED ON IT APPROXIMATELY 200' (60 m) IN ADVANCE OF THE MAIN ROUTE.
 - THE CLOSED PORTION OF THE MAIN ROUTE SHALL BE PROTECTED BY BLOCKING WITH TYPE I OR TYPE III BARRICADES, 1/3 OF THE CROSS SECTION OF THE CLOSED PORTION.
 - SIDE ROAD WITH A SPEED LIMIT GREATER THAN 40 MPH (60 km/h) AS SHOWN ON THE DRAWING AND AS DIRECTED BY THE ENGINEER.
 - ONE "ROAD CONSTRUCTION AHEAD" SIGN 48 X 48 (1.2 m x 1.2 m) WITH A FLASHER MOUNTED ON IT APPROXIMATELY 500' (150 m) IN ADVANCE OF THE MAIN ROUTE.
 - BLOCKING WITH TYPE III BARRICADES, 1/2 OF THE CROSS SECTION OF THE CLOSED PORTION.
 - CONES MAY BE SUBSTITUTED FOR BARRICADES OR DRUMS AT HALF THE SPACING DURING DAY OPERATIONS. CONES SHALL BE A MINIMUM OF 28' (7.10) IN HEIGHT.
 - SIGNING AND THE WORK ZONE, A SINGLE HEADED ARROW (M6-1) SHALL BE USED IN LIEU OF THE DOUBLE HEADED ARROW (M6-4).
- THE CLOSED PORTION OF THE MAIN ROUTE SHALL BE PROTECTED BY BLOCKING WITH TYPE III BARRICADES, 1/3 OF THE CROSS SECTION OF THE CLOSED PORTION.
- ADVANCE WARNING SIGNS ARE TO BE OMITTED ON DRIVEWAYS UNLESS OTHERWISE SPECIFIED IN THE PLANS OR BY THE ENGINEER.
- WHEN WORK IS BEING PERFORMED ON A SIDE ROAD OR DRIVEWAY, THE SIDE ROAD OR DRIVEWAY SHALL BE PROTECTED BY BARRICADES OR DRUMS AT HALF THE SPACING DURING DAY OPERATIONS. CONES SHALL BE A MINIMUM OF 28' (7.10) IN HEIGHT.
- WHEN THE SIDE ROAD LIES BETWEEN THE BEGINNING OF THE MAINLINE AND THE WORK ZONE, A SINGLE HEADED ARROW (M6-1) SHALL BE USED IN LIEU OF THE DOUBLE HEADED ARROW (M6-4).

All dimensions are in inches (millimeters) unless otherwise shown.

DESIGNED	L.A.A.	REVISED	A. HOUSLEY 08-15-16	STATE OF ILLINOIS	TRAFFIC CONTROL AND PROTECTION FOR	L.A. RFL	SECTION	T-11	TOTAL SHEETS	1
DRAWN		PROVED	T. BARMACHER 01-26-10	DEPARTMENT OF TRANSPORTATION	SIDE ROADS, INTERSECTIONS, AND DRIVEWAYS			CONTRACT NO.		
CHECKED		REVISED	A. SCHUEZLE 07-01-13							
DATE	06-83	REVISED	A. SCHUEZLE 09-15-16							
USER NAME	642081									
PLOT SCALE	1/8"=1'-0"									
PLOT DATE	06-08									

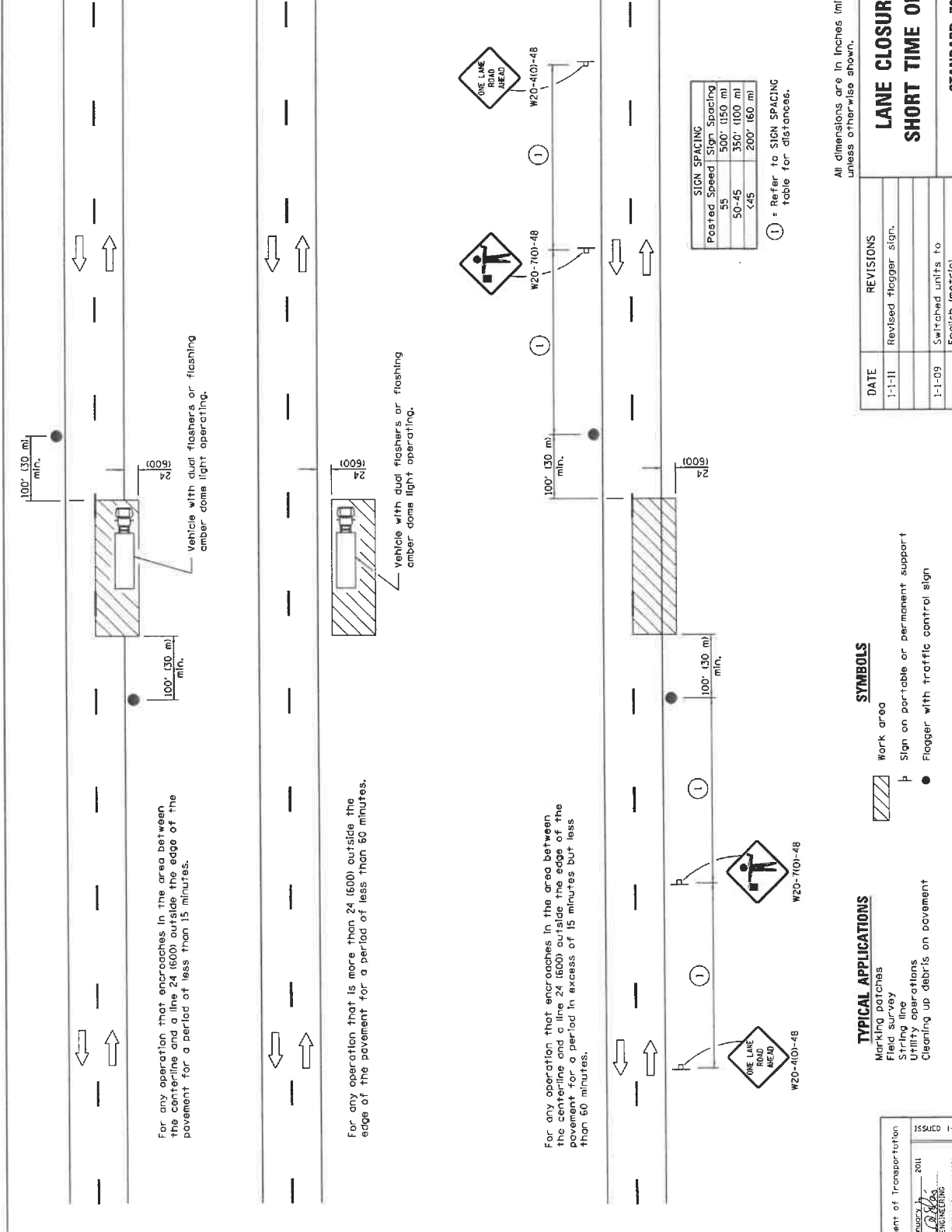

All dimensions are in inches (millimeters) unless otherwise shown.

LANE CLOSURE, 2L, 2W, SHORT TIME OPERATIONS

STANDARD 701301-04

DATE	REVISIONS
1-1-11	revised flagger sign.
1-1-09	Switched units to English (metric).

Illinois Department of Transportation
 APPROVED: [Signature] 2011
 ENGINEER OF SAFETY ENGINEERING
 APPROVED: [Signature] 2011
 ENGINEER OF DESIGN AND ENVIRONMENT

ISSUED 1-1-97

SPECIAL PROVISIONS

INDEX
FOR
SUPPLEMENTAL SPECIFICATIONS
AND RECURRING SPECIAL PROVISIONS

Adopted January 1, 2022

This index contains a listing of SUPPLEMENTAL SPECIFICATIONS, frequently used RECURRING SPECIAL PROVISIONS, and LOCAL ROADS AND STREETS RECURRING SPECIAL PROVISIONS.

No ERRATA this year.

SUPPLEMENTAL SPECIFICATIONS

Std. Spec. Sec.

Page No.

No Supplemental Specifications this year.



Local Public Agency	County	Section Number
County of DuPage	DuPage	22-03000-01-GM

Check this box for lettings prior to 01/01/2022.

The Following Recurring Special Provisions Indicated By An "X" Are Applicable To This Contract And Are Included By Reference:

Recurring Special Provisions

Check Sheet #		Reference Page No.
1	<input type="checkbox"/> Additional State Requirements for Federal-Aid Construction Contracts	1
2	<input type="checkbox"/> Subletting of Contracts (Federal-Aid Contracts)	4
3	<input type="checkbox"/> EEO	5
4	<input type="checkbox"/> Specific EEO Responsibilities Non Federal-Aid Contracts	15
5	<input type="checkbox"/> Required Provisions - State Contracts	20
6	<input type="checkbox"/> Asbestos Bearing Pad Removal	26
7	<input type="checkbox"/> Asbestos Waterproofing Membrane and Asbestos HMA Surface Removal	27
8	<input type="checkbox"/> Temporary Stream Crossings and In-Stream Work Pads	28
9	<input type="checkbox"/> Construction Layout Stakes	29
10	<input type="checkbox"/> Use of Geotextile Fabric for Railroad Crossing	32
11	<input type="checkbox"/> Subsealing of Concrete Pavements	34
12	<input type="checkbox"/> Hot-Mix Asphalt Surface Correction	38
13	<input type="checkbox"/> Pavement and Shoulder Resurfacing	40
14	<input type="checkbox"/> Patching with Hot-Mix Asphalt Overlay Removal	41
15	<input type="checkbox"/> Polymer Concrete	43
16	<input type="checkbox"/> PVC Pipeliner	45
17	<input type="checkbox"/> Bicycle Racks	46
18	<input type="checkbox"/> Temporary Portable Bridge Traffic Signals	48
19	<input type="checkbox"/> Nighttime Inspection of Roadway Lighting	50
20	<input type="checkbox"/> English Substitution of Metric Bolts	51
21	<input type="checkbox"/> Calcium Chloride Accelerator for Portland Cement Concrete	52
22	<input type="checkbox"/> Quality Control of Concrete Mixtures at the Plant	53
23	<input type="checkbox"/> Quality Control/Quality Assurance of Concrete Mixtures	61
24	<input type="checkbox"/> Digital Terrain Modeling for Earthwork Calculations	77
25	<input type="checkbox"/> Preventive Maintenance - Bituminous Surface Treatment (A-1)	79
26	<input type="checkbox"/> Temporary Raised Pavement Markers	85
27	<input type="checkbox"/> Restoring Bridge Approach Pavements Using High-Density Foam	86
28	<input type="checkbox"/> Portland Cement Concrete Inlay or Overlay	89
29	<input type="checkbox"/> Portland Cement Concrete Partial Depth Hot-Mix Asphalt Patching	93
30	<input type="checkbox"/> Longitudinal Joint and Crack Patching	96
31	<input type="checkbox"/> Concrete Mix Design - Department Provided	98
32	<input type="checkbox"/> Station Numbers in Pavements or Overlays	99

County of DuPage

DuPage

22-03000-01-GM

The Following Local Roads And Streets Recurring Special Provisions Indicated By An "X" Are Applicable To This Contract And Are Included By Reference:

Local Roads And Streets Recurring Special Provisions

<u>Check Sheet #</u>		<u>Page No.</u>
LRS 1	Reserved	101
LRS 2	<input type="checkbox"/> Furnished Excavation	102
LRS 3	<input checked="" type="checkbox"/> Work Zone Traffic Control Surveillance	103
LRS 4	<input checked="" type="checkbox"/> Flaggers in Work Zones	104
LRS 5	<input checked="" type="checkbox"/> Contract Claims	105
LRS 6	<input checked="" type="checkbox"/> Bidding Requirements and Conditions for Contract Proposals	106
LRS 7	<input type="checkbox"/> Bidding Requirements and Conditions for Material Proposals	112
LRS 8	Reserved	118
LRS 9	<input type="checkbox"/> Bituminous Surface Treatments	119
LRS 10	Reserved	123
LRS 11	<input checked="" type="checkbox"/> Employment Practices	124
LRS 12	<input checked="" type="checkbox"/> Wages of Employees on Public Works	126
LRS 13	<input checked="" type="checkbox"/> Selection of Labor	128
LRS 14	<input type="checkbox"/> Paving Brick and Concrete Paver Pavements and Sidewalks	129
LRS 15	<input checked="" type="checkbox"/> Partial Payments	132
LRS 16	<input checked="" type="checkbox"/> Protests on Local Lettings	133
LRS 17	<input checked="" type="checkbox"/> Substance Abuse Prevention Program	134
LRS 18	<input type="checkbox"/> Multigrade Cold Mix Asphalt	135
LRS 19	<input type="checkbox"/> Reflective Crack Control Treatment	136

STATE OF ILLINOIS

SPECIAL PROVISIONS

The following Special Provisions supplement the "Standard Specifications for Road and Bridge Construction", adopted April 1, 2022, the latest edition of the "Manual on Uniform Traffic Control Devices for Streets and Highways", the "Manual of Test Procedures for Materials" in effect on the date of invitation for bids and the "Supplemental Specifications and Recurring Special Provisions" indicated on the Check Sheet included herein which apply to and govern the proposed improvement designated as **Section 22-03000-01-GM**, and in case of conflict with any part or parts of said Specifications, the said Special Provisions shall take precedence and shall govern.

BIDDING REQUIREMENTS AND CONDITIONS FOR CONTRACT PROPOSALS

(Illinois Department of Transportation Bureau of Local Roads and Streets Special Provision for BIDDING REQUIREMENTS AND CONDITIONS FOR CONTRACT PROPOSALS LRS Check Sheet #6)

Add the following to the section **Prequalification of Bidders**: "Prequalification is required. The Certificate of Eligibility shall be accompanied by a Request for Authorization to Bid form completed by the prospective bidder. The Certificate of Eligibility and Request for Authorization to Bid shall be submitted at least one business day prior to the public opening of proposals. Authorization to bid will be issued by the DuPage County Division of Transportation to prospective bidders who are qualified to perform the work, as evidenced by the Certificate of Eligibility."

Revise the first sentence of the section **Preparation of the Proposal** to read: "Bidders shall submit their proposals on the form furnished by the Awarding Authority or on a form approved by the Awarding Authority prior to submittal of the Proposal."

Add the following to the section Preparation of the Proposal: "Unit prices shall only be accepted rounded to the nearest one-hundredth (0.01) of a dollar."

Add the following to the section Preparation of the Proposal: "The low bidder shall complete and submit the IRS W-9 form included in this proposal within 48 hours of being notified as the low bidder. The form shall be emailed to Department at DOTBidinfo@dupageco.org. All bidders may either submit the W-9 form with their bid proposal or wait to be notified that they are the low bidder.

Add the following to the section **Public Opening of Proposals**: "Proposals will only be accepted by bidders who have been issued an authorization to bid by the DuPage County Division of Transportation. Proposals submitted without authorization to bid will be returned unopened."

Add the following to after the first sentence of the section **Consideration of Proposals**: "If the Proposal includes quantities and unit prices for multiple agencies, then the summation to be compared shall include all items and not just the items for a single agency."

Revise the first sentence of the section **Award of Contract** to read: "The award of contract will be made within 60 calendar days after the opening of proposals to the lowest responsible and qualified bidder whose proposal complies with all the requirements prescribed.

Revise the last sentence of the section **Award of Contract** to read: "If a contract is not awarded within 60 days after the opening of proposals, bidders may file a written request with the Awarding Authority for the withdrawal of their bid, and the Awarding Authority will permit such withdrawal.

SCOPE OF WORK

This project involves the HMA Resurfacing of various streets as shown on the accompanying plan sheet.

This project consists of the construction of HMA Surface Removal (2" at Butt Joints and Drives), 3" Patching, HMA Poly Level Binder (M.M.) N50, 4.75, a nominal 1.5" HMA Surface Course, and Aggregate Shoulders.

The Highway Commissioner and Engineer reserve the right to delete, decrease, or increase certain pay items, in accordance with Article 104.02 of the *Standard Specifications*. No additional compensation will be allowed for any deletions or decreases in the Contract.

SECTION 107 LEGAL REGULATIONS AND RESPONSIBILITY TO PUBLIC

The Department will provide forms or a website for the Contractors and Subcontractors to enter and submit vendor information to comply with Public Act 102-0265. In order to minimize inconvenience to local residents, strict adherence to Article 107.09 will be required. Arrangements must be made with Downers Grove Township Road District for adequate notice to residents regarding parking prohibitions during construction. Access through the construction area and to each driveway shall be provided at all times.

In case of temporary road closures, the Contractor shall notify all affected Fire Protection Districts, Law Enforcement Agencies, Governmental Agencies, and School Districts at least seventy-two (72) hours prior to said road closure. The Contractor shall insure that the road is in passable condition at the end of each day's work.

Contractor is responsible for distributing "Resident Notification Letter" that would alert residents about upcoming work in the area seventy-two (72) hours prior to the start of any construction operations.

Article 107.20 Protection and Restoration of Property. Add the following after the first paragraph of this Article:

"The Contractor shall maintain conveyance of all flows during construction of this project. When existing drainage facilities are disturbed, the Contractor shall provide and maintain temporary inlets, outlets, and connections for all private and public drains, sewers,

culverts, and other drainage facilities. The Contractor shall provide facilities to take in all storm water which will be received by these drains and sewers and discharge the same. The Contractor shall provide and maintain a pumping plant, if necessary, and a temporary outlet and be prepared at all times to dispose of water received from these temporary connections until such time that the permanent drainage facilities are in service.”

Revise the last paragraph of this Article to read:

“The cost of all materials and equipment required and all labor necessary to comply with the above Provisions will not be paid for separately but shall be considered as included in the unit bid prices of the contract, and no additional compensation will be allowed.”

Article 107.26 Indemnification. In addition to the requirements of this Article, for any activity occurring on an easement or any other property not owned by the Department, the indemnification shall also be extended to the property owners and any tenants thereon.

Article 107.27 Insurance. In addition to the requirements of this Article, the policies of insurance for Commercial (Comprehensive) General Liability and Commercial (Comprehensive) Automobile Liability shall include an additional insured endorsement naming the County of DuPage, its officers and employees and Downers Grove Township Road District, its officers, and employees as additional insureds. The endorsements shall be on forms acceptable to the County of DuPage. This additional insured is to be on a primary and non-contributory basis and include a Waiver of Subrogation endorsement.

Employer’s Liability insurance shall be in an amount not less than one million (\$1,000,000.00) dollars each accident/injury and one million (\$1,000,000.00) dollars each employee/disease. It is the duty of the Contractor to immediately notify the County of DuPage and the Downers Grove Township Road District if any insurance required under this contract has been cancelled, materially changed, or renewal has been refused, and the Contractor shall immediately suspend all work in progress and take the necessary steps to purchase, maintain and provide the required insurance coverage. If a suspension of work should occur due to insurance requirements, upon verification by the County of DuPage of the required insurance coverage, the County of DuPage shall notify the Contractor that the Contractor can proceed with the work that is a part of this contract. Failure to provide and maintain the required insurance coverage could result in the immediate cancellation of this contract, and the Contractor shall accept and bear all costs that may result from the cancellation of this contract due to Contractor's failure to provide and maintain the required insurance.

Limits of Umbrella Excess Liability (over primary) shall not be less than an amount that in combination with Commercial General Liability totals \$6,000,000 of liability insurance per occurrence. The Umbrella Excess Liability Policy shall include in the “Who is Insured” pages of the policy wording such as “Any other person or organization you have agreed in a written contract to provide additional insurance” or wording to that affect. The contractor shall provide a copy of said section of the excess/umbrella liability policy upon request by the County of DuPage.

The Contractor shall require all subcontractors to maintain the same insurance coverage required of the contractor. The County of DuPage retains the right to obtain evidence of subcontractor insurance coverage at any time.

Article 107.36 Dust Control The Contractor will be required to have available a water truck or similar equipment to control dust. If necessary, the Contractor shall be required to control dust during non-working hours.

SECTION 108 PROSECUTION AND PROGRESS

Article 108.03 Prosecution of the Work. Revise the first sentence of this Article to read, "The Contractor shall not begin the work to be performed under the contract without written authorization from the DuPage County Division of Transportation to proceed with the work and shall commence work not later than 10 days after receiving the authorization to proceed."

SECTION 109 MEASUREMENT AND PAYMENT

Article 109.08 Acceptance and Final Payment. Add the following to this Article: "Prior to final payment, an affidavit from the Contractor will be required."

MOBILIZATION (SECTION 671)

Article 671.02. Basis of Payment. Revise this article to read: "Basis of Payment. This work will not be paid for separately but shall be included in the various items of work."

TRAFFIC CONTROL

Traffic Control shall be according to the applicable sections of the Standard Specifications, the Supplemental Specifications, the Special Provision for Work Zone Traffic Control (Illinois Department of Transportation Check Sheet #LRS3), the "Illinois Manual on Uniform Traffic Control Devices for Streets and Highways," any special details and Highway Standards contained in the plans, and the Special Provisions contained herein.

Special attention is called to Article 107.09 of the Standard Specifications and the following Highway Standards, Details, Qualify Standard for Work Zone Traffic Control Devices, Recurring Special Provisions and Special Provisions contained herein, relating to traffic control.

The Contractor shall contact the Engineer at least seventy-two (72) hours in advance of beginning work.

STANDARDS:

701301-04: Lane Closure, 2L, 2W, Short Time Operations
701501-06: Urban Lane Closure, 2L, 2W, Undivided
701901-08: Traffic Control Devices

DETAILS:

TC-10: Traffic Control and Protection for Side Roads, Intersections, and Driveways,
TC-13: District One Typical Pavement Markings

All signage is to be in place prior to the beginning of construction operations. All construction operations shall be conducted in a manner to ensure minimum hindrance to traffic using the road in the area of the project.

In no case shall the pavement be closed to traffic during non-working hours by excavating outside the limits of the pavement, by waste dirt, by equipment, or other operations. The traveled portion of the pavement shall not be blocked by loading, backfilling, or hauling equipment.

The pavement must be kept clean at all times. If conditions warrant, the pavement and shoulder area shall be bladed and/or swept several times a day to the satisfaction of the Engineer.

Failure to comply with these provisions shall be considered just cause for the Engineer to suspend the work by written notice until these provisions are complied with.

The Contractor shall obtain, erect, maintain and remove all signs, barricades, flashers, cones, snow fencing, flagmen and other traffic control devices as may be necessary for the purpose of regulating, warning, or guiding traffic and the public. Placement and maintenance of all traffic control devices shall be as directed by the Engineer and the Township Road District and in accordance with the applicable parts of Article 107.14 of the STANDARD SPECIFICATIONS and the Illinois Manual on Uniform Traffic Control Devices for Streets and Highways, and to the following standards:

The Contractor shall provide the necessary flagmen to re-route traffic as required by the Township. It is the responsibility of the Contractor to protect and maintain barricades for the duration of the project. All streets shall be passable and remain open at the end of the workday.

At the pre-construction meeting, the Contractor shall furnish the name of the individual in his direct employ who is to be responsible for the installation and maintenance of the Traffic Control for this project. If the actual installation and maintenance are to be accomplished by subcontractor, consent shall be requested of the Engineer at the time of the pre-construction meeting in accordance with Article 108.01 of the STANDARD SPECIFICATIONS. This shall not relieve the Contractor to the foregoing requirement for a responsible individual in his direct employ to supervise this work.

The Contractor shall provide the name, address, and telephone number of three responsible employees, all of which shall be available on twenty-four (24) hour call to respond to emergencies involving the construction site. These employees shall have the

ability and capacity to operate the necessary equipment to provide for the safety of the public.

Basis of Payment: This work will be paid for at the contract unit price as a LUMP SUM item (LS) for **TRAFFIC CONTROL & PROTECTION**.

PROTECTION AND RESTORATION OF PROPERTY (ARTICLE 107.20)

This item will comply with the requirements of Article 107.20 and Sections 729 and 730 of the *Standard Specifications*, as modified herein:

The Contractor will take care to protect all mailboxes along the route of construction. Should it be necessary to relocate any mailboxes during construction, as directed by the Engineer, the Contractor shall contact the Postmaster to determine the proper locations for the mailboxes.

The Contractor will take care to protect all signs along the route of construction. Should it be necessary to relocate any of these signs during construction, as directed by the Engineer, the Contractor shall contact the Engineer to determine the locations of the signs.

The cost of all materials required and all labor necessary to comply with the relocation of mailboxes and/or signs shall not be paid for separately but shall be considered as included in the unit prices bid for the Contract, and no additional compensation will be allowed.

PROSECUTION OF THE WORK (SECTION 108)

Article 108.03 Prosecution of the Work. Revise the first sentence of this Article to read, "The Contractor shall not begin the work to be performed under the Contract without written authorization from the Engineer to proceed with the work and will commence work no later than ten (10) days after receiving the authorization to proceed."

The Township Road District may be performing certain maintenance operations on various roads to be resurfaced under this Contract. Before any paving operations are begun, the Contractor must contact the Township Highway Commissioner for approval to begin construction a minimum of forty-eight (48) hours in advance.

No additional compensation will be allowed to the Contractor for delays caused by the Township Road District's maintenance.

NOTIFICATION TO ENGINEER (ARTICLE 108.02)

This item will comply with the requirements of Article 108.02 of the *Standard Specifications*, as modified herein:

The Contractor will notify both the Downer Grove Township Highway Commissioner and the Engineer at least forty-eight (48) hours prior to the commencement of any work. Limits of construction will be laid out in conjunction with the Engineer.

All materials must be approved by the State of Illinois, and certified inspection tickets will be furnished to the Engineer.

SCHEDULING OF WORK (ARTICLE 108.02)

This item will comply with the requirements of Article 108.02 of the *Standard Specifications*, as modified herein:

Downers Grove Township Road District has a policy of informing all homeowners in advance of operations. (See article 107.09)

The Contractor will be required to furnish a project schedule to Morris Engineering, Inc. approximately one (1) week prior to construction.

All work shall be completed by **10/10/2022** after notification to proceed has been given, otherwise penalties will be assessed to the Contractor as provided for in Article 108.09 of the *Standard Specifications*.

PROTECTION OF EXISTING PLANT MATERIAL (ARTICLE 201.05)

This item will be performed in accordance with the applicable parts of Article 201.05 of the *Standard Specifications*, with the following exceptions:

No trees shall be removed under this Contract. Overhanging limbs are to be trimmed or cut off to provide sufficient clearance for all equipment used on this project, including raised dump trucks. Limb pruning shall be performed by a licensed tree expert and will be undertaken in advance of construction. All limbs, branches, and other debris resulting from this work will be disposed of by the Contractor according to Article 202.03.

The contractor shall prevent damage to parkway trees caused by construction equipment and contamination of the bituminous materials from branches and leaves. The cost of this work will not be paid for separately but will be considered as included in the unit prices bid for the Contract and no additional compensation will be allowed.

BITUMINOUS MATERIALS – TACK COAT (ARTICLE 406.05)

This item will comply with the requirements of Section 406.05 of the *Standard Specifications*, as modified herein:

Tack coat will be applied at a rate of 0.10 gallon per square yard on previously paved areas over the entire surface of the roadway before leveling binder is constructed. All roads will be swept to the satisfaction of the Engineer before priming. Cost of sweeping will be considered included in the unit price bid for Bituminous Materials (Tack Coat).

Special precautions must be taken to adequately warn motorists of the fresh tack. Metal signs will be placed at the beginning and end of each section. Metal signs, or an approved equal, will be mounted at all side roads and will be removed when the Tack Coat has cured. The Contractor will be liable for all damage claims arising from failure to adequately warn motorists.

The following special conditions apply to the Tack Coat. Any deviation must be approved by the Engineer.

1. Tack will not be applied more than twenty-four (24) hours before a section of road is resurfaced.
2. Only one-half of the road will be tacked at a time unless the road can be blocked, and traffic detoured around the priming. Sufficient signs, flagmen, etc., will be used to ensure that motorists do not travel on the Tack until it has cured.
3. If a temporary detour cannot be utilized, one-way traffic will be maintained.
4. Priming hours will be determined by the Engineer for each section of roadway.
5. If traffic cannot be kept off fresh Tack with the above procedures, the Engineer may require priming to be done in immediate conjunction with the paving operation.

Payment will be made at the contract unit price per pound (**LB**) for **BITUMINOUS MATERIALS (TACK COAT)**.

HOT-MIX ASPHALT (D-1)

Effective: January 1, 2022

Revised: August 1, 2022

Replace Article 1030.09(g)(1) of the Standard Specifications with the following:

“(1) The Contractor shall sample approximately 150 lb (70 kg) of mix as required for the Department’s random mixture verification tests according to Article 1030.09(h)(1).”

Replace the second sentence of Article 1030.09(h)(1) of the Standard Specifications with the following:

“The Engineer will randomly identify one sample for each 3,000 tons (2,720 metric tons) of mix, with a minimum of one sample per mix. If the remaining mix quantity is 600 tons (544 metric tons) or less, the quantity will be combined with the previous 3,000 tons (2,720 metric tons) in the Engineer’s random sample identification. If the required tonnage of a mixture for a single pay item is less than 250 tons (225 metric tons) in total, the Engineer will waive mixture verification tests.”

Add the following to the end of the third paragraph of Article 1030.09(h)(2) of the Standard Specifications:

“The HMA maximum theoretical specific gravity (G_{mm}) will be based on the Department mixture verification test. If there is more than one Department mixture verification G_{mm} test, the G_{mm} will be based on the average of the Department test results.”

FRICION AGGREGATE (D1)

Effective: January 1, 2011
Revised: December 1, 2021

Revise Article 1004.03(a) of the Standard Specifications to read:

“1004.03 Coarse Aggregate for Hot-Mix Asphalt (HMA). The aggregate shall be according to Article 1004.01 and the following.

(a) Description. The coarse aggregate for HMA shall be according to the following table.

Use	Mixture	Aggregates Allowed
Class A	Seal or Cover	<u>Allowed Alone or in Combination</u> ^{5/} : Gravel Crushed Gravel Carbonate Crushed Stone Crystalline Crushed Stone Crushed Sandstone Crushed Slag (ACBF) Crushed Steel Slag Crushed Concrete
HMA Low ESAL	Stabilized Subbase or Shoulders	<u>Allowed Alone or in Combination</u> ^{5/} : Gravel Crushed Gravel Carbonate Crushed Stone Crystalline Crushed Stone Crushed Sandstone Crushed Slag (ACBF) Crushed Steel Slag ^{1/} Crushed Concrete
HMA High ESAL Low ESAL	Binder IL-19.0 or IL-19.0L SMA Binder	<u>Allowed Alone or in Combination</u> ^{5/} ^{6/} : Crushed Gravel Carbonate Crushed Stone ^{2/} Crystalline Crushed Stone Crushed Sandstone Crushed Slag (ACBF) Crushed Concrete ^{3/}

Use	Mixture	Aggregates Allowed	
HMA High ESAL Low ESAL	C Surface and Binder IL-9.5 IL-9.5FG or IL-9.5L	<u>Allowed Alone or in Combination</u> ^{5/} : Crushed Gravel Carbonate Crushed Stone ^{2/} Crystalline Crushed Stone Crushed Sandstone Crushed Slag (ACBF) Crushed Steel Slag ^{4/} Crushed Concrete ^{3/}	
HMA High ESAL	D Surface and Binder IL-9.5 or IL-9.5FG	<u>Allowed Alone or in Combination</u> ^{5/} : Crushed Gravel Carbonate Crushed Stone (other than Limestone) ^{2/} Crystalline Crushed Stone Crushed Sandstone Crushed Slag (ACBF) Crushed Steel Slag ^{4/}	
		<u>Other Combinations Allowed:</u>	
		<i>Up to...</i>	<i>With...</i>
		25% Limestone	Dolomite
		50% Limestone	Any Mixture D aggregate other than Dolomite
75% Limestone	Crushed Slag (ACBF) or Crushed Sandstone		
HMA High ESAL	E Surface IL-9.5 SMA Ndesign 80 Surface	<u>Allowed Alone or in Combination</u> ^{5/} ^{6/} : Crushed Gravel Crystalline Crushed Stone Crushed Sandstone Crushed Slag (ACBF) Crushed Steel Slag No Limestone.	
		<u>Other Combinations Allowed:</u>	
		<i>Up to...</i>	<i>With...</i>
		50% Dolomite ^{2/}	Any Mixture E aggregate

Use	Mixture	Aggregates Allowed	
		75% Dolomite ^{2/}	Crushed Sandstone, Crushed Slag (ACBF), Crushed Steel Slag, or Crystalline Crushed Stone
		75% Crushed Gravel ^{2/}	Crushed Sandstone, Crystalline Crushed Stone, Crushed Slag (ACBF), or Crushed Steel Slag
HMA High ESAL	F Surface IL-9.5 SMA Ndesign 80 Surface	<u>Allowed Alone or in Combination</u> ^{5/} ^{6/} : Crystalline Crushed Stone Crushed Sandstone Crushed Slag (ACBF) Crushed Steel Slag No Limestone.	
		<u>Other Combinations Allowed:</u>	
		<i>Up to...</i>	<i>With...</i>
		50% Crushed Gravel ^{2/} or Dolomite ^{2/}	Crushed Sandstone, Crushed Slag (ACBF), Crushed Steel Slag, or Crystalline Crushed Stone

- 1/ Crushed steel slag allowed in shoulder surface only.
- 2/ Carbonate crushed stone (limestone) and/or crushed gravel shall not be used in SMA Ndesign 80.
- 3/ Crushed concrete will not be permitted in SMA mixes.
- 4/ Crushed steel slag shall not be used as binder.
- 5/ When combinations of aggregates are used, the blend percent measurements shall be by volume.”
- 6/ Combining different types of aggregate will not be permitted in SMA Ndesign 80.”

HOT-MIX ASPHALT – MIXTURE DESIGN VERIFICATION AND PRODUCTION (D1)

Effective: January 1, 2019
 Revised: December 1, 2021

Add to Article 1030.05 (d)(3) of the Standard Specifications to read:

“ During mixture design, prepared samples shall be submitted to the District laboratory by the Contractor for verification testing. The required testing, and number and size of prepared samples submitted, shall be according to the following tables.

High ESAL – Required Samples for Verification Testing	
Mixture	Hamburg Wheel and I-FIT Testing ^{1/2/}
Binder	total of 3 - 160 mm tall bricks
Surface	total of 4 - 160 mm tall bricks

Low ESAL – Required Samples for Verification Testing	
Mixture	I-FIT Testing ^{1/2/}
Binder	1 - 160 mm tall brick
Surface	2 - 160 mm tall bricks

1/ The compacted gyratory bricks for Hamburg wheel and I-FIT testing shall be 7.5 ± 0.5 percent air voids.

2/ If the Contractor does not possess the equipment to prepare the 160 mm tall brick(s), twice as many 115 mm tall compacted gyratory bricks will be acceptable.

Revise the fourth paragraph of Article 1030.10 of the Standard Specifications to read:

“When a test strip is not required, each HMA mixture shall still be sampled on the first day of production: I-FIT and Hamburg wheel testing for High ESAL; I-FIT testing for Low ESAL. Within two working days after sampling the mixture, the Contractor shall deliver gyratory cylinders to the District laboratory for Department verification testing. The High ESAL mixture test results shall meet the requirements of Articles 1030.05(d)(3) and 1030.05(d)(4). The Low ESAL mixture test results shall meet the requirements of Article 1030.05(d)(4). The required number and size of prepared samples submitted for the Hamburg wheel and I-FIT testing shall be according to the “High ESAL - Required Samples for Verification Testing” table in Article 1030.05(d)(3) above.”

Add the following to the end of Article 1030.10 of the Standard Specifications to read:

“Mixture sampled during first day of production shall include approximately 60 lb (27 kg) of additional material for the Department to conduct Hamburg wheel testing and approximately 80 lb (36 kg) of additional material for the Department to conduct I-FIT testing. Within two working days after sampling, the Contractor shall deliver prepared samples to the District laboratory for verification testing. The required number and size of prepared samples submitted for the Hamburg wheel and I-FIT testing shall be

according to the "High ESAL - Required Samples for Verification Testing" table in Article 1030.05(d)(3) above."

AGGREGATE SHOULDERS TY B (SECTION 481)

This item will comply with the requirements of Section 481 of the *Standard Specifications*, as modified herein:

This work will consist of the construction of a 2' wide aggregate shoulder, along non-curbed streets or as designated by the Engineer. The width and depth of the aggregate shoulders may vary and on some portions of road. Quantities may be increased or decreased by any amount with no change to the unit price.

Virgin CA-6 Grade 8 limestone shall be used in the construction of the shoulders. RAP may not be used under this item.

Payment will be made at the contract unit price per **TON** of **AGGREGATE SHOULDER, TYPE B**.

COMPLETION AND FINAL PUNCHLIST

After all work on this project is complete, the Engineer will prepare a final "Punchlist" of items that have not been completed to the satisfaction of the Highway Commissioner or Engineer, which require correction prior to final acceptance. Upon issuance of the final "Punchlist," the Contractor will have fifteen (15) calendar days to complete all work outstanding. The Engineer will re-inspect the project to determine if all work has been completed. If all work is not complete within the initial fifteen (15) day period, the final payment estimate will be held from approval until all work has been completed satisfactorily. No additional compensation will be allowed for "Punchlist" work.

PAYMENT ESTIMATES

Payment requests will be submitted to the Engineer for review and approval. The Engineer will prepare and submit a recommendation of payment to DuPage County. All payments for work performed will be made by DuPage County from Downers Grove Township Road District Motor Fuel Tax (MFT) Funds. Final Payment will not be made until all inspections and material tickets have been received by the Engineer.

All materials must be approved by the State of Illinois and certified tickets shall be furnished to the Engineer.

DuPage County Prevailing Wage Rates posted on 5/18/2022

Trade Title	Rg	Type	C	Base	Foreman	Overtime				H/W	Pension	Vac	Trng	Other Ins
						M-F	Sa	Su	Hol					
ASBESTOS ABT-GEN	All	ALL		45.90	46.90	1.5	1.5	2.0	2.0	16.55	14.71	0.00	0.90	
ASBESTOS ABT-MEC	All	BLD		38.85	41.96	1.5	1.5	2.0	2.0	14.42	12.61	0.00	0.82	
BOILERMAKER	All	BLD		53.66	58.48	2.0	2.0	2.0	2.0	6.97	23.69	0.00	2.67	
BRICK MASON	All	BLD		48.56	53.42	1.5	1.5	2.0	2.0	11.70	21.06	0.00	1.03	
CARPENTER	All	ALL		50.86	52.86	1.5	1.5	2.0	2.0	11.79	24.76	0.00	0.79	
CEMENT MASON	All	ALL		47.50	49.50	2.0	1.5	2.0	2.0	16.75	20.74	0.00	1.00	
CERAMIC TILE FINISHER	All	BLD		42.80	42.80	1.5	1.5	2.0	2.0	11.45	14.27	0.00	0.94	
COMMUNICATION TECHNICIAN	All	BLD		34.71	37.51	1.5	1.5	2.0	2.0	12.85	23.75	3.20	0.68	0.10
ELECTRIC PWR EQMT OP	All	ALL		46.06	62.84	1.5	1.5	2.0	2.0	6.75	12.90	0.00	1.15	1.38
ELECTRIC PWR GRNDMAN	All	ALL		35.38	62.84	1.5	1.5	2.0	2.0	6.75	9.91	0.00	0.88	1.06
ELECTRIC PWR LINEMAN	All	ALL		55.37	62.84	1.5	1.5	2.0	2.0	6.75	15.50	0.00	1.38	1.66
ELECTRIC PWR TRK DRV	All	ALL		36.67	62.84	1.5	1.5	2.0	2.0	6.75	10.27	0.00	0.92	1.10
ELECTRICIAN	All	BLD		41.83	46.08	1.5	1.5	2.0	2.0	12.85	27.00	6.85	0.95	0.10
ELEVATOR CONSTRUCTOR	All	BLD		60.42	67.97	2.0	2.0	2.0	2.0	15.87	19.31	4.83	0.64	
FENCE ERECTOR	NE	ALL		45.67	47.67	1.5	1.5	2.0	2.0	13.68	16.39	0.00	0.65	
FENCE ERECTOR	W	ALL		48.83	52.74	2.0	2.0	2.0	2.0	13.31	25.25	0.00	1.28	
GLAZIER	All	BLD		47.60	49.10	1.5	2.0	2.0	2.0	14.99	23.55	0.00	1.43	
HEAT/FROST INSULATOR	All	BLD		51.80	54.91	1.5	1.5	2.0	2.0	14.42	15.36	0.00	0.82	
IRON WORKER	E	ALL		54.51	56.51	2.0	2.0	2.0	2.0	15.40	25.06	0.00	0.44	
IRON WORKER	W	ALL		48.83	52.74	2.0	2.0	2.0	2.0	13.31	25.25	0.00	1.28	
LABORER	All	ALL		45.90	46.65	1.5	1.5	2.0	2.0	16.55	14.71	0.00	0.90	
LATHER	All	ALL		50.86	52.86	1.5	1.5	2.0	2.0	11.79	24.76	0.00	0.79	
MACHINIST	All	BLD		50.68	53.18	1.5	1.5	2.0	2.0	8.93	8.95	1.85	1.47	
MARBLE FINISHER	All	ALL		37.00	50.10	1.5	1.5	2.0	2.0	11.70	19.10	0.00	0.93	
MARBLE MASON	All	BLD		47.71	52.48	1.5	1.5	2.0	2.0	11.70	20.53	0.00	1.02	
MATERIAL TESTER I	All	ALL		35.90		1.5	1.5	2.0	2.0	16.55	14.71	0.00	0.90	
MATERIALS TESTER II	All	ALL		40.90		1.5	1.5	2.0	2.0	16.55	14.71	0.00	0.90	
MILLWRIGHT	All	ALL		50.86	52.86	1.5	1.5	2.0	2.0	11.79	24.76	0.00	0.79	
OPERATING ENGINEER	All	BLD	1	53.60	57.60	2.0	2.0	2.0	2.0	21.40	18.60	2.00	2.40	
OPERATING ENGINEER	All	BLD	2	52.30	57.60	2.0	2.0	2.0	2.0	21.40	18.60	2.00	2.40	
OPERATING ENGINEER	All	BLD	3	49.75	57.60	2.0	2.0	2.0	2.0	21.40	18.60	2.00	2.40	

OPERATING ENGINEER	All	BLD	4	48.00	57.60	2.0	2.0	2.0	2.0	21.40	18.60	2.00	2.40	
OPERATING ENGINEER	All	BLD	5	57.35	57.60	2.0	2.0	2.0	2.0	21.40	18.60	2.00	2.40	
OPERATING ENGINEER	All	BLD	6	54.60	57.60	2.0	2.0	2.0	2.0	21.40	18.60	2.00	2.40	
OPERATING ENGINEER	All	BLD	7	56.60	57.60	2.0	2.0	2.0	2.0	21.40	18.60	2.00	2.40	
OPERATING ENGINEER	All	FLT		41.00	41.00	1.5	1.5	2.0	2.0	20.90	17.85	2.00	2.15	
OPERATING ENGINEER	All	HWY	1	51.80	55.80	1.5	1.5	2.0	2.0	21.40	18.60	2.00	2.40	
OPERATING ENGINEER	All	HWY	2	51.25	55.80	1.5	1.5	2.0	2.0	21.40	18.60	2.00	2.40	
OPERATING ENGINEER	All	HWY	3	49.20	55.80	1.5	1.5	2.0	2.0	21.40	18.60	2.00	2.40	
OPERATING ENGINEER	All	HWY	4	47.80	55.80	1.5	1.5	2.0	2.0	21.40	18.60	2.00	2.40	
OPERATING ENGINEER	All	HWY	5	46.60	55.80	1.5	1.5	2.0	2.0	21.40	18.60	2.00	2.40	
OPERATING ENGINEER	All	HWY	6	54.80	55.80	1.5	1.5	2.0	2.0	21.40	18.60	2.00	2.40	
OPERATING ENGINEER	All	HWY	7	52.80	55.80	1.5	1.5	2.0	2.0	21.40	18.60	2.00	2.40	
ORNAMENTAL IRON WORKER	E	ALL		52.13	54.63	2.0	2.0	2.0	2.0	14.23	23.99	0.00	1.25	
ORNAMENTAL IRON WORKER	W	ALL		48.83	52.74	2.0	2.0	2.0	2.0	13.31	25.25	0.00	1.28	
PAINTER	All	ALL		49.30	51.30	1.5	1.5	1.5	2.0	19.08	4.15	0.00	1.10	
PAINTER - SIGNS	All	BLD		41.55	46.67	1.5	1.5	2.0	2.0	3.04	3.90	0.00	0.00	
PILEDRIVER	All	ALL		50.86	52.86	1.5	1.5	2.0	2.0	11.79	24.76	0.00	0.79	
PIPEFITTER	All	BLD		52.00	55.00	1.5	1.5	2.0	2.0	11.60	21.85	0.00	2.92	
PLASTERER	All	BLD		48.60	51.52	1.5	1.5	2.0	2.0	11.70	20.98	0.00	1.02	
PLUMBER	All	BLD		52.80	55.95	1.5	1.5	2.0	2.0	16.45	16.75	0.00	1.47	
ROOFER	All	BLD		46.70	50.70	1.5	1.5	2.0	2.0	11.58	14.56	0.00	0.96	
SHEETMETAL WORKER	All	BLD		51.83	54.42	1.5	1.5	2.0	2.0	11.22	19.08	0.00	1.45	2.46
SPRINKLER FITTER	All	BLD		52.25	55.00	1.5	1.5	2.0	2.0	14.20	18.60	0.00	0.75	
STEEL ERECTOR	E	ALL		54.51	56.51	2.0	2.0	2.0	2.0	15.40	25.06	0.00	0.44	
STEEL ERECTOR	W	ALL		48.83	52.74	2.0	2.0	2.0	2.0	13.31	25.25	0.00	1.28	
STONE MASON	All	BLD		48.56	53.42	1.5	1.5	2.0	2.0	11.70	21.06	0.00	1.03	
TERRAZZO FINISHER	All	BLD		44.54	44.54	1.5	1.5	2.0	2.0	11.45	16.64	0.00	0.97	
TERRAZZO MASON	All	BLD		48.38	51.88	1.5	1.5	2.0	2.0	11.45	18.10	0.00	1.00	
TILE MASON	All	BLD		49.75	53.75	1.5	1.5	2.0	2.0	11.45	17.98	0.00	1.02	
TRAFFIC SAFETY WORKER I	All	HWY		38.50	40.10	1.5	1.5	2.0	2.0	8.90	8.90	0.00	0.90	
TRAFFIC SAFETY WORKER II	ALL	HWY		39.50	41.10	1.5	1.5	2.0	2.0	8.90	8.90	0.00	0.90	
TRUCK DRIVER	All	ALL	1	40.06	40.61	1.5	1.5	2.0	2.0	10.15	13.57	0.00	0.15	
TRUCK DRIVER	All	ALL	2	40.21	40.61	1.5	1.5	2.0	2.0	10.15	13.57	0.00	0.15	
TRUCK DRIVER	All	ALL	3	40.41	40.61	1.5	1.5	2.0	2.0	10.15	13.57	0.00	0.15	
TRUCK DRIVER	All	ALL	4	40.61	40.61	1.5	1.5	2.0	2.0	10.15	13.57	0.00	0.15	
TUCKPOINTER	All	BLD		48.25	49.25	1.5	1.5	2.0	2.0	8.79	20.47	0.00	1.01	

Legend

Rg Region

Type Trade Type - All,Highway,Building,Floating,Oil & Chip,Rivers

C Class

Base Base Wage Rate

OT M-F Unless otherwise noted, OT pay is required for any hour greater than 8 worked each day, Mon through Fri. The number listed is the multiple of the base wage.

OT Sa Overtime pay required for every hour worked on Saturdays

OT Su Overtime pay required for every hour worked on Sundays

OT Hol Overtime pay required for every hour worked on Holidays

H/W Health/Welfare benefit

Vac Vacation

Trng Training

Other Ins Employer hourly cost for any other type(s) of insurance provided for benefit of worker.

Explanations DUPAGE COUNTY

IRON WORKERS AND FENCE ERECTOR (WEST) - West of Route 53.

The following list is considered as those days for which holiday rates of wages for work performed apply: New Years Day, Memorial Day, Fourth of July, Labor Day, Thanksgiving Day, Christmas Day and Veterans Day in some classifications/counties. Generally, any of these holidays which fall on a Sunday is celebrated on the following Monday. This then makes work performed on that Monday payable at the appropriate overtime rate for holiday pay. Common practice in a given local may alter certain days of celebration. If in doubt, please check with IDOL.

EXPLANATION OF CLASSES

ASBESTOS - GENERAL - removal of asbestos material/mold and hazardous materials from any place in a building, including mechanical systems where those mechanical systems are to be removed. This includes the removal of asbestos materials/mold and hazardous materials from ductwork or pipes in a building when the building is to be demolished at the time or at some close future date.

ASBESTOS - MECHANICAL - removal of asbestos material from mechanical systems, such as pipes, ducts, and boilers, where the mechanical systems are to remain.

TRAFFIC SAFETY Worker I

Traffic Safety Worker I - work associated with the delivery, installation, pick-up and servicing of safety devices during periods of roadway construction, including such work as set-up and maintenance of barricades, barrier wall reflectors, drums, cones, delineators, signs, crash attenuators, glare screen and other such items, and the layout and application or removal of conflicting and/or temporary roadway markings utilized to control traffic in construction zones, as well as flagging for these operations.

TRAFFIC SAFETY WORKER II

Work associated with the installation and removal of permanent pavement markings and/or pavement markers including both installations performed by hand and installations performed by truck.

CERAMIC TILE FINISHER

The grouting, cleaning, and polishing of all classes of tile, whether for interior or exterior purposes, all burned, glazed or unglazed products; all composition materials, granite tiles, warning detectable tiles, cement tiles, epoxy composite materials, pavers, glass, mosaics, fiberglass, and all substitute materials, for tile made in tile-like units; all mixtures in tile like form of cement, metals, and other materials that are for and intended for use as a finished floor surface, stair treads, promenade roofs, walks, walls, ceilings, swimming pools, and all other places where tile is to form a finished interior or exterior. The mixing of all setting mortars including but not limited to thin-set mortars, epoxies, wall mud, and any other sand and cement mixtures or adhesives when used in the preparation, installation, repair, or maintenance of tile and/or similar materials. The handling and unloading of all sand, cement, lime, tile, fixtures, equipment, adhesives, or any other materials to be used in the preparation, installation, repair, or maintenance of tile and/or similar materials. Ceramic Tile Finishers shall fill all joints and voids regardless of method on all tile work, particularly and especially after installation of said tile work. Application of any and all protective coverings to all types of tile installations including, but not be limited to, all soap compounds, paper products, tapes, and all polyethylene coverings, plywood, masonite, cardboard, and any new type of products that may be used to protect tile installations, Blastrac equipment, and all floor scarifying equipment used in preparing floors to receive tile. The clean up and removal of all waste and materials. All demolition of existing tile floors and walls to be re-tiled.

COMMUNICATIONS TECHNICIAN

Low voltage installation, maintenance and removal of telecommunication facilities (voice, sound, data and video) including telephone and data inside wire, interconnect, terminal equipment, central offices, PABX, fiber optic cable and equipment, micro waves, V-SAT, bypass, CATV, WAN (wide area networks), LAN (local area networks), and ISDN (integrated system digital network), pulling of wire in raceways, but not the installation of raceways.

MARBLE FINISHER

Loading and unloading trucks, distribution of all materials (all stone, sand, etc.), stocking of floors with material, performing all rigging for heavy work, the handling of all material that may be needed for the installation of such materials, building of scaffolding, polishing if needed, patching, waxing of material if damaged, pointing up, caulking, grouting and cleaning of marble, holding water on diamond or Carborundum blade or saw for setters cutting, use of tub saw or any other saw needed for preparation of material, drilling of holes for wires that anchor material set by setters, mixing up of molding plaster for installation of material, mixing up thin set for the installation of material, mixing up of sand to cement for the installation of material and such other work as may be required in helping a Marble Setter in the handling of all material in the erection or installation of interior marble, slate, travertine, art marble, serpentine, alberene stone, blue stone, granite and other stones (meaning as to stone any foreign or domestic materials as are specified and used in building interiors and exteriors and customarily known as stone in the trade), carrara, sanionyx, vitrolite and similar opaque glass and the laying of all marble tile, terrazzo tile, slate tile and precast tile, steps, risers treads, base, or any other materials that may be used as substitutes for any of the aforementioned materials and which are used on interior and exterior which are installed in a similar manner.

MATERIAL TESTER I: Hand coring and drilling for testing of materials; field inspection of uncured concrete and asphalt.

MATERIAL TESTER II: Field inspection of welds, structural steel, fireproofing, masonry, soil, facade, reinforcing steel, formwork, cured concrete, and concrete and asphalt batch plants; adjusting proportions of bituminous mixtures.

OPERATING ENGINEER - BUILDING

Class 1. Asphalt Plant; Asphalt Spreader; Autograde; Backhoes with Caisson Attachment; Batch Plant; Benoto (requires Two Engineers); Boiler and Throttle Valve; Caisson Rigs; Central Redi-Mix Plant; Combination Back Hoe Front End-loader Machine; Compressor and Throttle Valve; Concrete Breaker (Truck Mounted); Concrete Conveyor; Concrete Conveyor (Truck Mounted); Concrete Paver Over 27E cu. ft; Concrete Paver 27E cu. ft. and Under; Concrete Placer; Concrete Placing Boom; Concrete Pump (Truck Mounted); Concrete Tower; Cranes, All; Cranes, Hammerhead; Cranes, (GCI and similar Type); Creter Crane; Spider Crane; Crusher, Stone, etc.; Derricks, All; Derricks, Traveling; Formless Curb and Gutter Machine; Grader, Elevating; Grouting Machines;

Heavy Duty Self-Propelled Transporter or Prime Mover; Highlift Shovels or Front Endloader 2-1/4 yd. and over; Hoists, Elevators, outside type rack and pinion and similar machines; Hoists, One, Two and Three Drum; Hoists, Two Tugger One Floor; Hydraulic Backhoes; Hydraulic Boom Trucks; Hydro Vac (and similar equipment); Locomotives, All; Motor Patrol; Lubrication Technician; Manipulators; Pile Drivers and Skid Rig; Post Hole Digger; Pre-Stress Machine; Pump Cretes Dual Ram; Pump Cretes: Squeeze Cretes-Screw Type Pumps; Gypsum Bulker and Pump; Raised and Blind Hole Drill; Roto Mill Grinder; Scoops - Tractor Drawn; Slip-Form Paver; Straddle Buggies; Operation of Tie Back Machine; Tournapull; Tractor with Boom and Side Boom; Trenching Machines.

Class 2. Boilers; Broom, All Power Propelled; Bulldozers; Concrete Mixer (Two Bag and Over); Conveyor, Portable; Forklift Trucks; Highlift Shovels or Front Endloaders under 2-1/4 yd.; Hoists, Automatic; Hoists, Inside Elevators; Hoists, Sewer Dragging Machine; Hoists, Tugger Single Drum; Laser Screed; Rock Drill (Self-Propelled); Rock Drill (Truck Mounted); Rollers, All; Steam Generators; Tractors, All; Tractor Drawn Vibratory Roller; Winch Trucks with "A" Frame.

Class 3. Air Compressor; Combination Small Equipment Operator; Generators; Heaters, Mechanical; Hoists, Inside Elevators (remodeling or renovation work); Hydraulic Power Units (Pile Driving, Extracting, and Drilling); Pumps, over 3" (1 to 3 not to exceed a total of 300 ft.); Low Boys; Pumps, Well Points; Welding Machines (2 through 5); Winches, 4 Small Electric Drill Winches.

Class 4. Bobcats and/or other Skid Steer Loaders; Oilers; and Brick Forklift.

Class 5. Assistant Craft Foreman.

Class 6. Gradall.

Class 7. Mechanics; Welders.

OPERATING ENGINEERS - HIGHWAY CONSTRUCTION

Class 1. Asphalt Plant; Asphalt Heater and Planer Combination; Asphalt Heater Scarfire; Asphalt Spreader; Autograder/GOMACO or other similar type machines: ABG Paver; Backhoes with Caisson Attachment; Ballast Regulator; Belt Loader; Caisson Rigs; Car Dumper; Central Redi-Mix Plant; Combination Backhoe Front Endloader Machine, (1 cu. yd. Backhoe Bucket or over or with attachments); Concrete Breaker (Truck Mounted); Concrete Conveyor; Concrete Paver over 27E cu. ft.; Concrete Placer; Concrete Tube Float; Cranes, all attachments; Cranes, Tower Cranes of all types: Creter Crane: Spider Crane; Crusher, Stone, etc.; Derricks, All; Derrick Boats; Derricks, Traveling; Dredges; Elevators, Outside type Rack & Pinion and Similar Machines; Formless Curb and Gutter Machine; Grader, Elevating; Grader, Motor Grader, Motor Patrol, Auto Patrol, Form Grader, Pull Grader, Subgrader; Guard Rail Post Driver Truck Mounted; Hoists, One, Two and Three Drum; Heavy Duty Self-Propelled Transporter or Prime Mover; Hydraulic Backhoes; Backhoes with shear attachments up to 40' of boom reach; Lubrication Technician; Manipulators; Mucking Machine; Pile Drivers and Skid Rig; Pre-Stress Machine; Pump Cretes Dual Ram; Rock Drill - Crawler or Skid Rig; Rock Drill - Truck Mounted; Rock/Track Tamper; Roto Mill Grinder; Slip-Form Paver; Snow Melters; Soil Test Drill Rig (Truck Mounted); Straddle Buggies; Hydraulic Telescoping Form (Tunnel); Operation of Tieback Machine; Tractor Drawn Belt Loader; Tractor Drawn Belt Loader (with attached pusher - two engineers); Tractor with Boom; Tractaire with Attachments; Traffic Barrier Transfer Machine; Trenching; Truck Mounted Concrete Pump with Boom; Raised or Blind Hole Drills (Tunnel Shaft); Underground Boring and/or Mining Machines 5 ft. in diameter and over tunnel, etc; Underground Boring and/or Mining Machines under 5 ft. in diameter; Wheel Excavator; Widener (APSCO).

Class 2. Batch Plant; Bituminous Mixer; Boiler and Throttle Valve; Bulldozers; Car Loader Trailing Conveyors; Combination Backhoe Front Endloader Machine (Less than 1 cu. yd. Backhoe Bucket or over or with attachments); Compressor and Throttle Valve; Compressor, Common Receiver (3); Concrete Breaker or Hydro Hammer; Concrete Grinding Machine; Concrete Mixer or Paver 7S Series to and including 27 cu. ft.; Concrete Spreader; Concrete Curing Machine, Burlap Machine, Belting Machine and Sealing Machine; Concrete Wheel Saw; Conveyor Muck Cars (Haglund or Similar Type); Drills, All; Finishing Machine - Concrete; Highlift Shovels or Front Endloader; Hoist - Sewer Dragging Machine; Hydraulic Boom Trucks (All Attachments); Hydro-Blaster; Hydro

Excavating (excluding hose work); Laser Screed; All Locomotives, Dinky; Off-Road Hauling Units (including articulating) Non Self-Loading Ejection Dump; Pump Cretes: Squeeze Cretes - Screw Type Pumps, Gypsum Bulker and Pump; Roller, Asphalt; Rotary Snow Plows; Rototiller, Seaman, etc., self-propelled; Self-Propelled Compactor; Spreader - Chip - Stone, etc.; Scraper - Single/Twin Engine/Push and Pull; Scraper - Prime Mover in Tandem (Regardless of Size); Tractors pulling attachments, Sheeps Foot, Disc, Compactor, etc.; Tug Boats.

Class 3. Boilers; Brooms, All Power Propelled; Cement Supply Tender; Compressor, Common Receiver (2); Concrete Mixer (Two Bag and Over); Conveyor, Portable; Farm-Type Tractors Used for Mowing, Seeding, etc.; Forklift Trucks; Grouting Machine; Hoists, Automatic; Hoists, All Elevators; Hoists, Tugger Single Drum; Jeep Diggers; Low Boys; Pipe Jacking Machines; Post-Hole Digger; Power Saw, Concrete Power Driven; Pug Mills; Rollers, other than Asphalt; Seed and Straw Blower; Steam Generators; Stump Machine; Winch Trucks with "A" Frame; Work Boats; Tamper-Form-Motor Driven.

Class 4. Air Compressor; Combination - Small Equipment Operator; Directional Boring Machine; Generators; Heaters, Mechanical; Hydraulic Power Unit (Pile Driving, Extracting, or Drilling); Light Plants, All (1 through 5); Pumps, over 3" (1 to 3 not to exceed a total of 300 ft.); Pumps, Well Points; Vacuum Trucks (excluding hose work); Welding Machines (2 through 5); Winches, 4 Small Electric Drill Winches.

Class 5. SkidSteer Loader (all); Brick Forklifts; Oilers.

Class 6. Field Mechanics and Field Welders

Class 7. Dowell Machine with Air Compressor; Gradall and machines of like nature.

OPERATING ENGINEER - FLOATING

Diver. Diver Wet Tender, Diver Tender, ROV Pilot, ROV Tender

TRUCK DRIVER - BUILDING, HEAVY AND HIGHWAY CONSTRUCTION

Class 1. Two or three Axle Trucks. A-frame Truck when used for transportation purposes; Air Compressors and Welding Machines, including those pulled by cars, pick-up trucks and tractors; Ambulances; Batch Gate Lockers; Batch Hopperman; Car and Truck Washers; Carry-alls; Fork Lifts and Hoisters; Helpers; Mechanics Helpers and Greasers; Oil Distributors 2-man operation; Pavement Breakers; Pole Trailer, up to 40 feet; Power Mower Tractors; Self-propelled Chip Spreader; Skipman; Slurry Trucks, 2-man operation; Slurry Truck Conveyor Operation, 2 or 3 man; Teamsters; Unskilled Dumpman; and Truck Drivers hauling warning lights, barricades, and portable toilets on the job site.

Class 2. Four axle trucks; Dump Crets and Adgetors under 7 yards; Dumpsters, Track Trucks, Euclids, Hug Bottom Dump Turnapulls or Turntrailers when pulling other than self-loading equipment or similar equipment under 16 cubic yards; Mixer Trucks under 7 yards; Ready-mix Plant Hopper Operator, and Winch Trucks, 2 Axles.

Class 3. Five axle trucks; Dump Crets and Adgetors 7 yards and over; Dumpsters, Track Trucks, Euclids, Hug Bottom Dump Turntrailers or turnapulls when pulling other than self-loading equipment or similar equipment over 16 cubic yards; Explosives and/or Fission Material Trucks; Mixer Trucks 7 yards or over; Mobile Cranes while in transit; Oil Distributors, 1-man operation; Pole Trailer, over 40 feet; Pole and Expandable Trailers hauling material over 50 feet long; Slurry trucks, 1-man operation; Winch trucks, 3 axles or more; Mechanic--Truck Welder and Truck Painter.

Class 4. Six axle trucks; Dual-purpose vehicles, such as mounted crane trucks with hoist and accessories; Foreman; Master Mechanic; Self-loading equipment like P.B. and trucks with scoops on the front.

TERRAZZO FINISHER

The handling of sand, cement, marble chips, and all other materials that may be used by the Mosaic Terrazzo Mechanic, and the

mixing, grinding, grouting, cleaning and sealing of all Marble, Mosaic, and Terrazzo work, floors, base, stairs, and wainscoting by hand or machine, and in addition, assisting and aiding Marble, Masonic, and Terrazzo Mechanics.

Other Classifications of Work:

For definitions of classifications not otherwise set out, the Department generally has on file such definitions which are available. If a task to be performed is not subject to one of the classifications of pay set out, the Department will upon being contacted state which neighboring county has such a classification and provide such rate, such rate being deemed to exist by reference in this document. If no neighboring county rate applies to the task, the Department shall undertake a special determination, such special determination being then deemed to have existed under this determination. If a project requires these, or any classification not listed, please contact IDOL at 217-782-1710 for wage rates or clarifications.

LANDSCAPING

Landscaping work falls under the existing classifications for laborer, operating engineer and truck driver. The work performed by landscape plantsman and landscape laborer is covered by the existing classification of laborer. The work performed by landscape operators (regardless of equipment used or its size) is covered by the classifications of operating engineer. The work performed by landscape truck drivers (regardless of size of truck driven) is covered by the classifications of truck driver.

MATERIAL TESTER & MATERIAL TESTER/INSPECTOR I AND II

Notwithstanding the difference in the classification title, the classification entitled "Material Tester I" involves the same job duties as the classification entitled "Material Tester/Inspector I". Likewise, the classification entitled "Material Tester II" involves the same job duties as the classification entitled "Material Tester/Inspector II".

COMPENSABLE DELAY COSTS (BDE)

Effective: June 2, 2017

Revised: April 1, 2019

Revise Article 107.40(b) of the Standard Specifications to read:

“(b) Compensation. Compensation will not be allowed for delays, inconveniences, or damages sustained by the Contractor from conflicts with facilities not meeting the above definition; or if a conflict with a utility in an unanticipated location does not cause a shutdown of the work or a documentable reduction in the rate of progress exceeding the limits set herein. The provisions of Article 104.03 notwithstanding, compensation for delays caused by a utility in an unanticipated location will be paid according to the provisions of this Article governing minor and major delays or reduced rate of production which are defined as follows.

- (1) Minor Delay. A minor delay occurs when the work in conflict with the utility in an unanticipated location is completely stopped for more than two hours, but not to exceed two weeks.
- (2) Major Delay. A major delay occurs when the work in conflict with the utility in an unanticipated location is completely stopped for more than two weeks.
- (3) Reduced Rate of Production Delay. A reduced rate of production delay occurs when the rate of production on the work in conflict with the utility in an unanticipated location decreases by more than 25 percent and lasts longer than seven calendar days.”

Revise Article 107.40(c) of the Standard Specifications to read:

“(c) Payment. Payment for Minor, Major, and Reduced Rate of Production Delays will be made as follows.

- (1) Minor Delay. Labor idled which cannot be used on other work will be paid for according to Article 109.04(b)(1) and (2) for the time between start of the delay and the minimum remaining hours in the work shift required by the prevailing practice in the area.

Equipment idled which cannot be used on other work, and which is authorized to standby on the project site by the Engineer, will be paid for according to Article 109.04(b)(4).

- (2) Major Delay. Labor will be the same as for a minor delay.

Equipment will be the same as for a minor delay, except Contractor-owned equipment will be limited to two weeks plus the cost of move-out to either the

Contractor's yard or another job and the cost to re-mobilize, whichever is less. Rental equipment may be paid for longer than two weeks provided the Contractor presents adequate support to the Department (including lease agreement) to show retaining equipment on the job is the most economical course to follow and in the public interest.

- (3) Reduced Rate of Production Delay. The Contractor will be compensated for the reduced productivity for labor and equipment time in excess of the 25 percent threshold for that portion of the delay in excess of seven calendar days. Determination of compensation will be in accordance with Article 104.02, except labor and material additives will not be permitted.

Payment for escalated material costs, escalated labor costs, extended project overhead, and extended traffic control will be determined according to Article 109.13."

Revise Article 108.04(b) of the Standard Specifications to read:

"(b) No working day will be charged under the following conditions.

- (1) When adverse weather prevents work on the controlling item.
- (2) When job conditions due to recent weather prevent work on the controlling item.
- (3) When conduct or lack of conduct by the Department or its consultants, representatives, officers, agents, or employees; delay by the Department in making the site available; or delay in furnishing any items required to be furnished to the Contractor by the Department prevents work on the controlling item.
- (4) When delays caused by utility or railroad adjustments prevent work on the controlling item.
- (5) When strikes, lock-outs, extraordinary delays in transportation, or inability to procure critical materials prevent work on the controlling item, as long as these delays are not due to any fault of the Contractor.
- (6) When any condition over which the Contractor has no control prevents work on the controlling item."

Revise Article 109.09(f) of the Standard Specifications to read:

"(f) Basis of Payment. After resolution of a claim in favor of the Contractor, any adjustment in time required for the work will be made according to Section 108. Any adjustment in the costs to be paid will be made for direct labor, direct materials, direct equipment, direct jobsite overhead, direct offsite overhead, and other direct costs allowed by the resolution. Adjustments in costs will not be made for interest charges, loss of anticipated profit, undocumented loss of efficiency, home office overhead and unabsorbed overhead

other than as allowed by Article 109.13, lost opportunity, preparation of claim expenses and other consequential indirect costs regardless of method of calculation.

The above Basis of Payment is an essential element of the contract and the claim cost recovery of the Contractor shall be so limited.”

Add the following to Section 109 of the Standard Specifications.

“109.13 Payment for Contract Delay. Compensation for escalated material costs, escalated labor costs, extended project overhead, and extended traffic control will be allowed when such costs result from a delay meeting the criteria in the following table.

Contract Type	Cause of Delay	Length of Delay
Working Days	Article 108.04(b)(3) or Article 108.04(b)(4)	No working days have been charged for two consecutive weeks.
Completion Date	Article 108.08(b)(1) or Article 108.08(b)(7)	The Contractor has been granted a minimum two week extension of contract time, according to Article 108.08.

Payment for each of the various costs will be according to the following.

- (a) Escalated Material and/or Labor Costs. When the delay causes work, which would have otherwise been completed, to be done after material and/or labor costs have increased, such increases will be paid. Payment for escalated material costs will be limited to the increased costs substantiated by documentation furnished by the Contractor. Payment for escalated labor costs will be limited to those items in Article 109.04(b)(1) and (2), except the 35 percent and 10 percent additives will not be permitted.
- (b) Extended Project Overhead. For the duration of the delay, payment for extended project overhead will be paid as follows.
 - (1) Direct Jobsite and Offsite Overhead. Payment for documented direct jobsite overhead and documented direct offsite overhead, including onsite supervisory and administrative personnel, will be allowed according to the following table.

Original Contract Amount	Supervisory and Administrative Personnel
Up to \$5,000,000	One Project Superintendent
Over \$ 5,000,000 - up to \$25,000,000	One Project Manager, One Project Superintendent or Engineer, and One Clerk
Over \$25,000,000 - up to \$50,000,000	One Project Manager, One Project Superintendent, One Engineer, and

	One Clerk
Over \$50,000,000	One Project Manager, Two Project Superintendents, One Engineer, and One Clerk

(2) Home Office and Unabsorbed Overhead. Payment for home office and unabsorbed overhead will be calculated as 8 percent of the total delay cost.

(c) Extended Traffic Control. Traffic control required for an extended period of time due to the delay will be paid for according to Article 109.04.

When an extended traffic control adjustment is paid under this provision, an adjusted unit price as provided for in Article 701.20(a) for increase or decrease in the value of work by more than ten percent will not be paid.

Upon payment for a contract delay under this provision, the Contractor shall assign subrogation rights to the Department for the Department's efforts of recovery from any other party for monies paid by the Department as a result of any claim under this provision. The Contractor shall fully cooperate with the Department in its efforts to recover from another party any money paid to the Contractor for delay damages under this provision."

CONSTRUCTION AIR QUALITY – DIESEL RETROFIT (BDE)

Effective: June 1, 2010

Revised: November 1, 2014

The reduction of emissions of particulate matter (PM) for off-road equipment shall be accomplished by installing retrofit emission control devices. The term "equipment" refers to diesel fuel powered devices rated at 50 hp and above, to be used on the jobsite in excess of seven calendar days over the course of the construction period on the jobsite (including rental equipment).

Contractor and subcontractor diesel powered off-road equipment assigned to the contract shall be retrofitted using the phased in approach shown below. Equipment that is of a model year older than the year given for that equipment's respective horsepower range shall be retrofitted:

Effective Dates	Horsepower Range	Model Year
June 1, 2010 ^{1/}	600-749	2002
	750 and up	2006
June 1, 2011 ^{2/}	100-299	2003
	300-599	2001
	600-749	2002
	750 and up	2006
June 1, 2012 ^{2/}	50-99	2004
	100-299	2003
	300-599	2001
	600-749	2002
	750 and up	2006

1/ Effective dates apply to Contractor diesel powered off-road equipment assigned to the contract.

2/ Effective dates apply to Contractor and subcontractor diesel powered off-road equipment assigned to the contract.

The retrofit emission control devices shall achieve a minimum PM emission reduction of 50 percent and shall be:

- a) Included on the U.S. Environmental Protection Agency (USEPA) *Verified Retrofit Technology List* (<http://www.epa.gov/cleandiesel/verification/verif-list.htm>), or verified by the California Air Resources Board (CARB) (<http://www.arb.ca.gov/diesel/verdev/vt/cvt.htm>); or
- b) Retrofitted with a non-verified diesel retrofit emission control device if verified retrofit emission control devices are not available for equipment proposed to be used on the project, and if the Contractor has obtained a performance certification from the retrofit

device manufacturer that the emission control device provides a minimum PM emission reduction of 50 percent.

Note: Large cranes (Crawler mounted cranes) which are responsible for critical lift operations are exempt from installing retrofit emission control devices if such devices adversely affect equipment operation.

Diesel powered off-road equipment with engine ratings of 50 hp and above, which are unable to be retrofitted with verified emission control devices or if performance certifications are not available which will achieve a minimum 50 percent PM reduction, may be granted a waiver by the Department if documentation is provided showing good faith efforts were made by the Contractor to retrofit the equipment.

Construction shall not proceed until the Contractor submits a certified list of the diesel powered off-road equipment that will be used, and as necessary, retrofitted with emission control devices. The list(s) shall include (1) the equipment number, type, make, Contractor/rental company name; and (2) the emission control devices make, model, USEPA or CARB verification number, or performance certification from the retrofit device manufacturer. Equipment reported as fitted with emissions control devices shall be made available to the Engineer for visual inspection of the device installation, prior to being used on the jobsite.

The Contractor shall submit an updated list of retrofitted off-road construction equipment as retrofitted equipment changes or comes on to the jobsite. The addition or deletion of any diesel powered equipment shall be included on the updated list.

If any diesel powered off-road equipment is found to be in non-compliance with any portion of this special provision, the Engineer will issue the Contractor a diesel retrofit deficiency deduction.

Any costs associated with retrofitting any diesel powered off-road equipment with emission control devices shall be considered as included in the contract unit prices bid for the various items of work involved and no additional compensation will be allowed. The Contractor's compliance with this notice and any associated regulations shall not be grounds for a claim.

Diesel Retrofit Deficiency Deduction

When the Engineer determines that a diesel retrofit deficiency exists, a daily monetary deduction will be imposed for each calendar day or fraction thereof the deficiency continues to exist. The calendar day(s) will begin when the time period for correction is exceeded and end with the Engineer's written acceptance of the correction. The daily monetary deduction will be \$1,000.00 for each deficiency identified.

The deficiency will be based on lack of diesel retrofit emissions control.

If a Contractor accumulates three diesel retrofit deficiency deductions for the same piece of equipment in a contract period, the Contractor will be shutdown until the deficiency is corrected.

Such a shutdown will not be grounds for any extension of the contract time, waiver of penalties, or be grounds for any claim.

80261

HOT-MIX ASPHALT (BDE)

Effective: January 1, 2022

Revised: August 1, 2022

Replace Article 1030.09(g)(1) of the Standard Specifications with the following:

“(1) The Contractor shall sample approximately 150 lb (70 kg) of mix as required for the Department’s random mixture verification tests according to Article 1030.09(h)(1).”

Replace the second sentence of Article 1030.09(h)(1) of the Standard Specifications with the following:

“The Engineer will randomly identify one sample for each 3,000 tons (2,720 metric tons) of mix, with a minimum of one sample per mix. If the remaining mix quantity is 600 tons (544 metric tons) or less, the quantity will be combined with the previous 3,000 tons (2,720 metric tons) in the Engineer’s random sample identification. If the required tonnage of a mixture for a single pay item is less than 250 tons (225 metric tons) in total, the Engineer will waive mixture verification tests.”

Add the following to the end of the third paragraph of Article 1030.09(h)(2) of the Standard Specifications:

“The HMA maximum theoretical specific gravity (G_{mm}) will be based on the Department mixture verification test. If there is more than one Department mixture verification G_{mm} test, the G_{mm} will be based on the average of the Department test results.”

Add the following paragraph between the third and four paragraphs of Article 1030.10 of the Standard Specifications:

“When a test strip is not required, each HMA mixture with a quantity of 3,000 tons (2,750 metric tons) or more shall still be sampled on the first day of production: I-FIT and Hamburg wheel testing for High ESAL; I-FIT testing for Low ESAL. Within two working days after sampling the mixture, the Contractor shall deliver gyratory cylinders to the District laboratory for Department verification testing. The High ESAL mixture test results shall meet the requirements of Articles 1030.05(d)(3) and 1030.05(d)(4). The Low ESAL mixture test results shall meet the requirements of Article 1030.05(d)(4).”

80442

SUBCONTRACTOR MOBILIZATION PAYMENTS (BDE)

Effective: November 2, 2017

Revised: April 1, 2019

Replace the second paragraph of Article 109.12 of the Standard Specifications with the following:

"This mobilization payment shall be made at least seven days prior to the subcontractor starting work. The amount paid shall be at the following percentage of the amount of the subcontract reported on form BC 260A submitted for the approval of the subcontractor's work.

Value of Subcontract Reported on Form BC 260A	Mobilization Percentage
Less than \$10,000	25%
\$10,000 to less than \$20,000	20%
\$20,000 to less than \$40,000	18%
\$40,000 to less than \$60,000	16%
\$60,000 to less than \$80,000	14%
\$80,000 to less than \$100,000	12%
\$100,000 to less than \$250,000	10%
\$250,000 to less than \$500,000	9%
\$500,000 to \$750,000	8%
Over \$750,000	7%"

80391

VEHICLE AND EQUIPMENT WARNING LIGHTS (BDE)

Effective: November 1, 2021

Add the following paragraph after the first paragraph of Article 701.08 of the Standard Specifications:

“The Contractor shall equip all vehicles and equipment with high-intensity oscillating, rotating, or flashing, amber or amber-and-white, warning lights which are visible from all directions. The lights shall be in operation while the vehicle or equipment is engaged in construction operations.”

80439